

Linear Graphs

T1

This problem gives you the chance to:

- show knowledge and understanding of linear graphs

$$y = 3$$

$$y = 2x + 6$$

$$2y + x = 0$$

$$y = \frac{1}{3}x$$

$$2y + x = 6$$

$$2y = -x \quad y = -\frac{1}{2}x$$

Here are the equations of some linear graphs.

1. Four of the graphs are drawn below.

a. Write the correct equation on each graph.

b. Draw the graph of the equation not used above on the diagram on the opposite page.

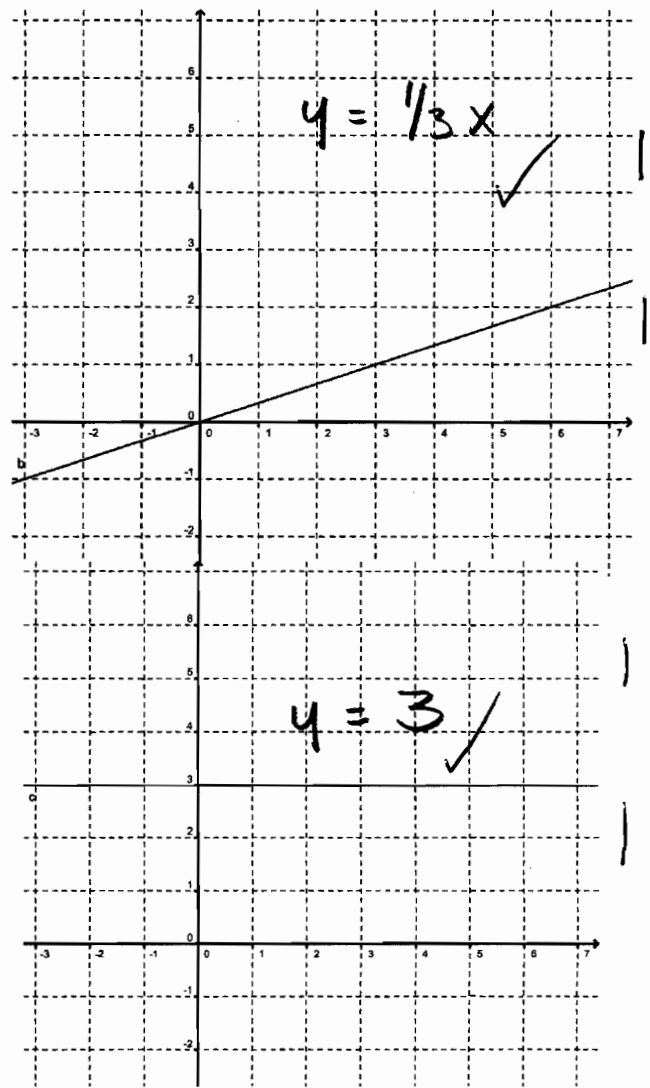
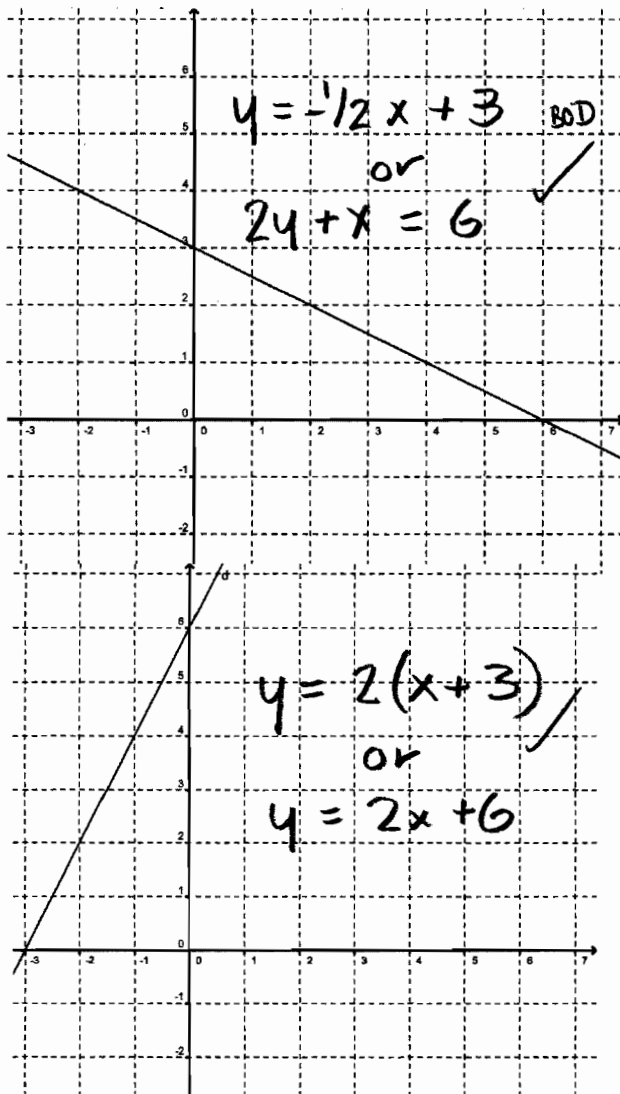

T1

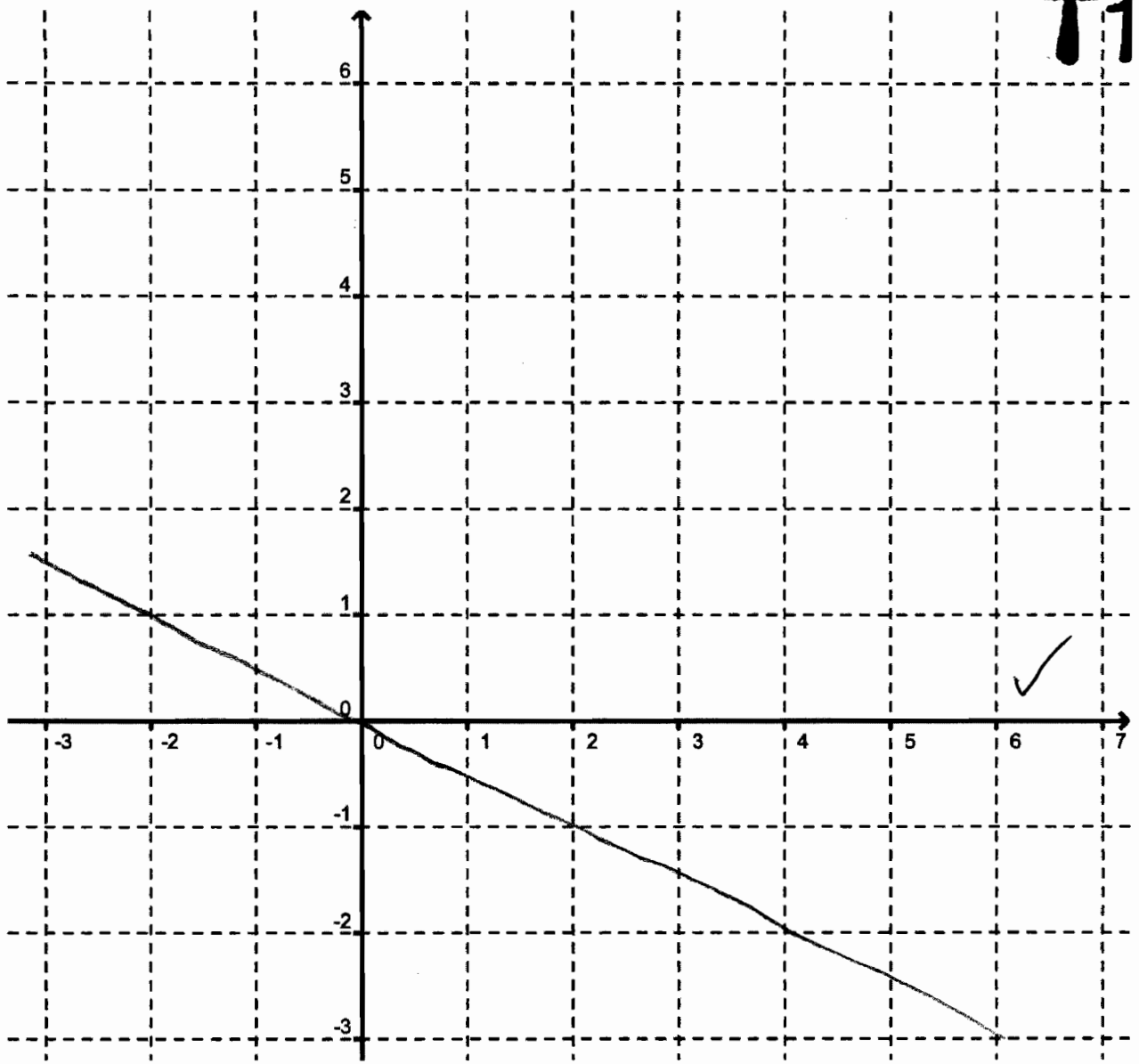

2. a. Which equation could represent the speed of someone walking steadily? $y = \frac{1}{3}x$
 Explain your reasoning.

This is time on the x and distance on y. ✓ 1
They are going slow at $\frac{1}{3}$ mile in 1 hour.

b. Which equation could represent the conversion between two different monetary currencies? 1

$y = \frac{1}{3}x$ ✓

Linear Graphs

T2

This problem gives you the chance to:

- show knowledge and understanding of linear graphs

Here are the equations of some linear graphs.

$$\frac{2y+x=0}{2} \\ y+\frac{1}{2}x=0$$

~~$y=3$~~
 ~~$y=2x+6$~~
 $2y+x=0$
 $y=\frac{1}{3}x$
 $2y+x=6$

~~$2y+x=0$~~
 ~~$2y=0-x$~~
 ~~2~~
 $y=0x$

~~$2y+x=6$~~
 ~~$2y=6-x$~~
 ~~2~~
 $y=3-x$

1. Four of the graphs are drawn below.

a. Write the correct equation on each graph.

b. Draw the graph of the equation not used above on the diagram on the opposite page.

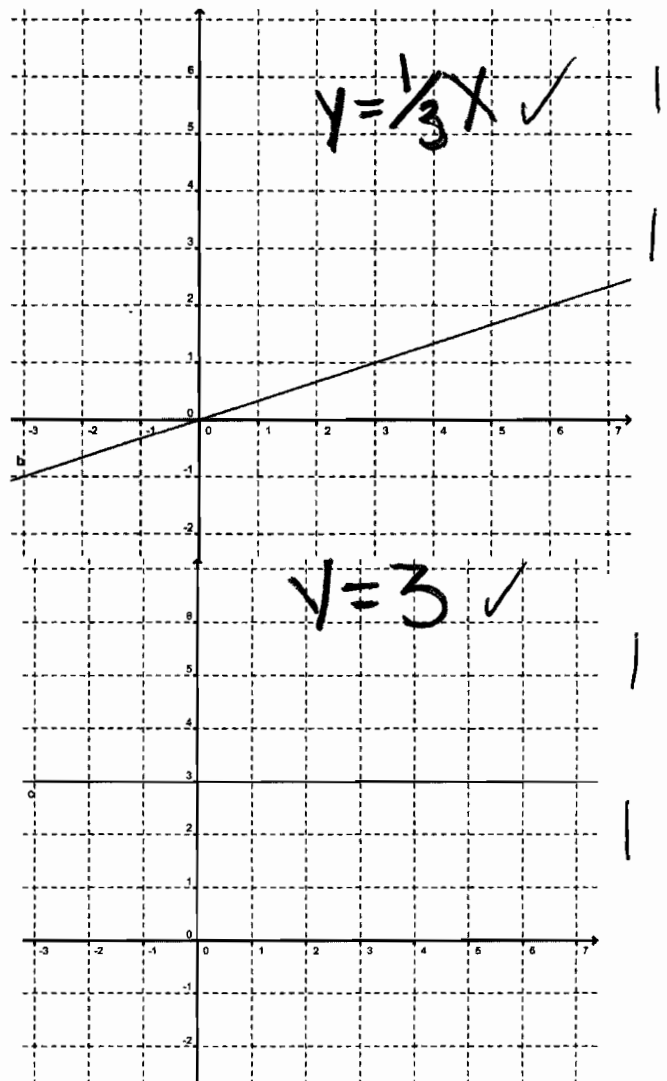
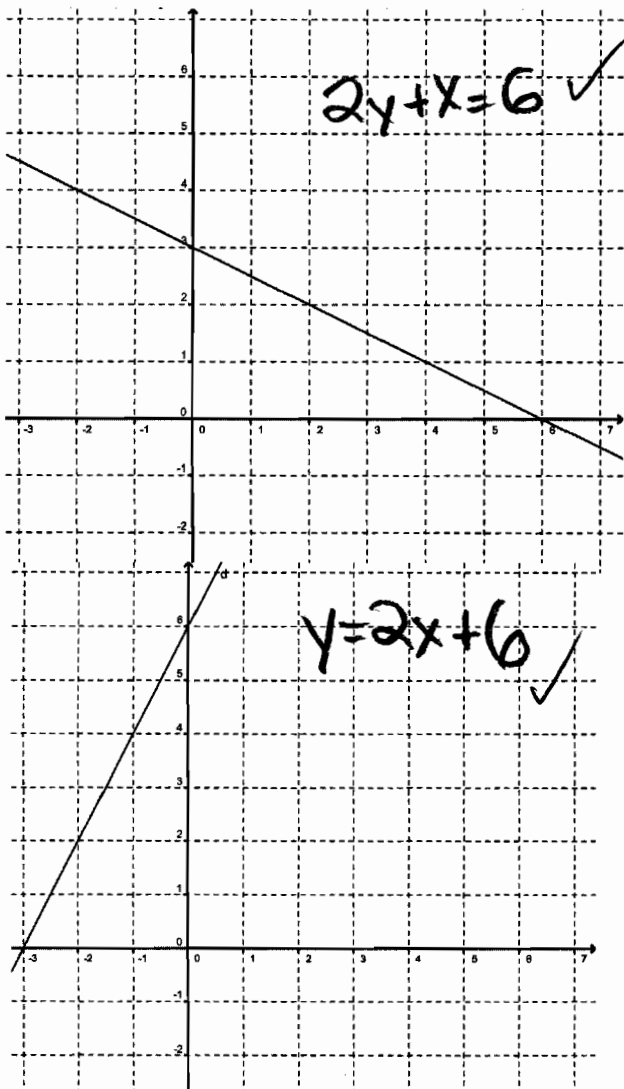

T2

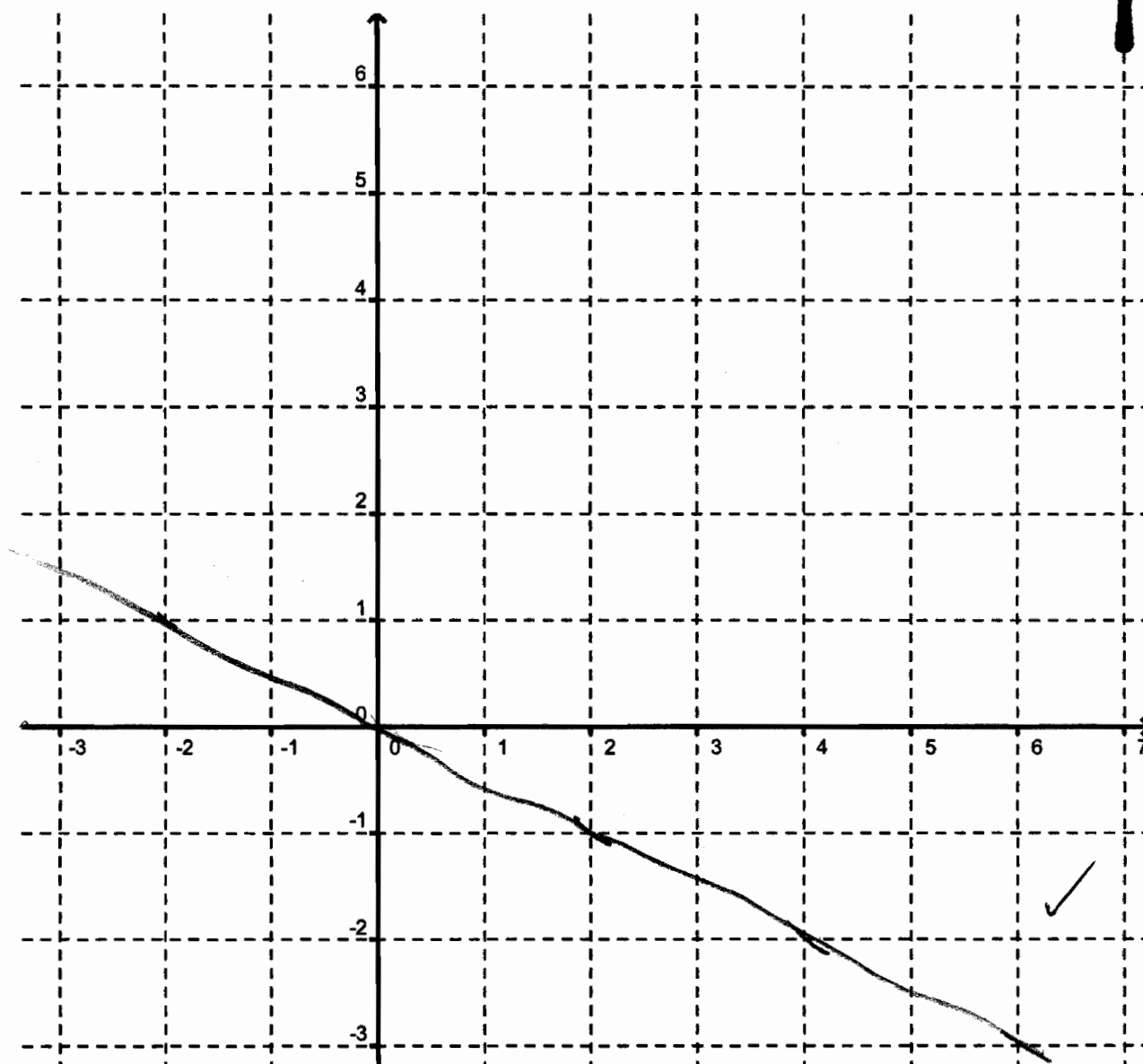

2. a. Which equation could represent the speed of someone walking steadily? $y = \frac{1}{3}x$
Explain your reasoning.

because the graph is going at
a equal rate. \uparrow

- b. Which equation could represent the conversion between two different monetary currencies?

$y = 2x + 6$ x 0

Linear Graphs

T3

This problem gives you the chance to:

- show knowledge and understanding of linear graphs

Here are the equations of some linear graphs.

~~$y = 3$~~
 ~~$y = 2x + 6$~~
 ~~$2x + x = 0$~~

~~$y = \frac{1}{3}x$~~

~~$2y + x = 6$~~
 ~~$-x - x$~~

$\frac{2y}{2} = \frac{6-x}{2}$

$y = 3 - \frac{1}{2}x$

1. Four of the graphs are drawn below.

a. Write the correct equation on each graph.

b. Draw the graph of the equation not used above on the diagram on the opposite page.

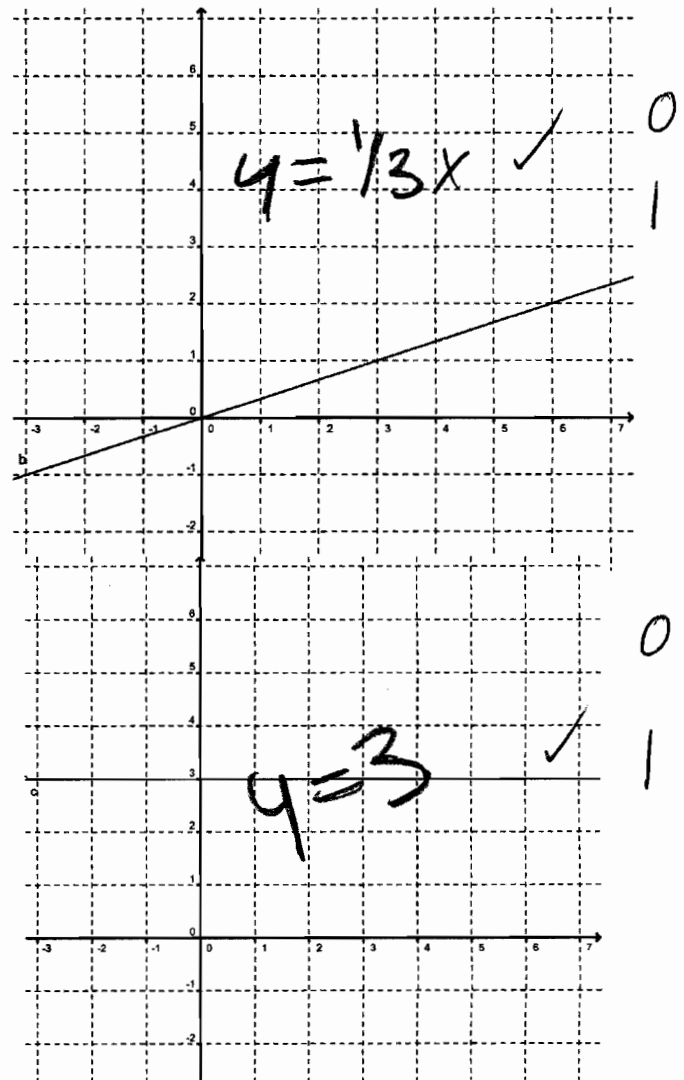
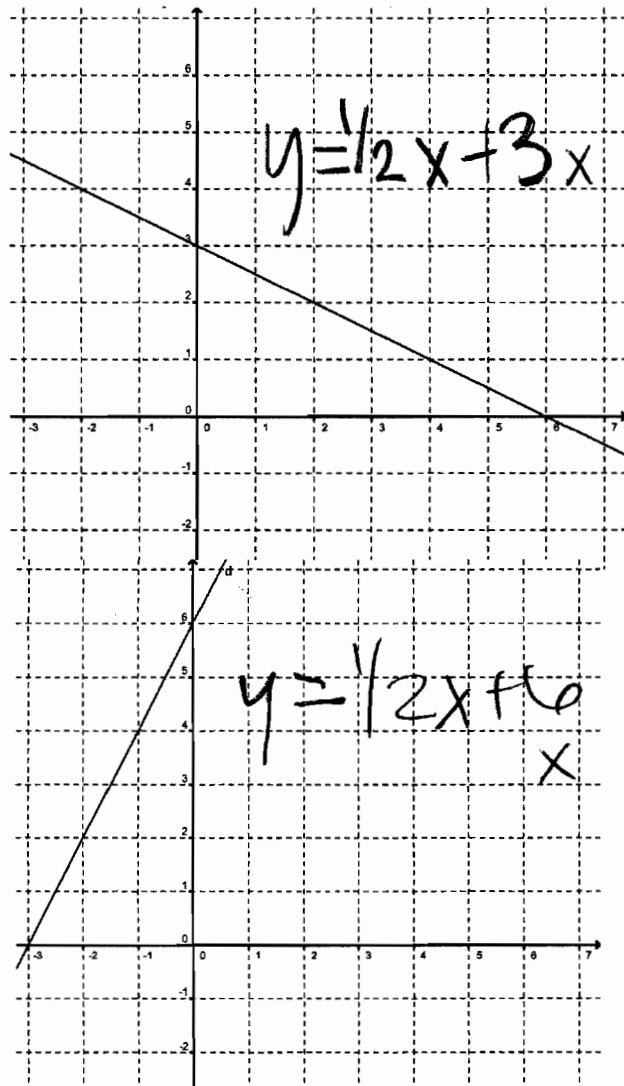

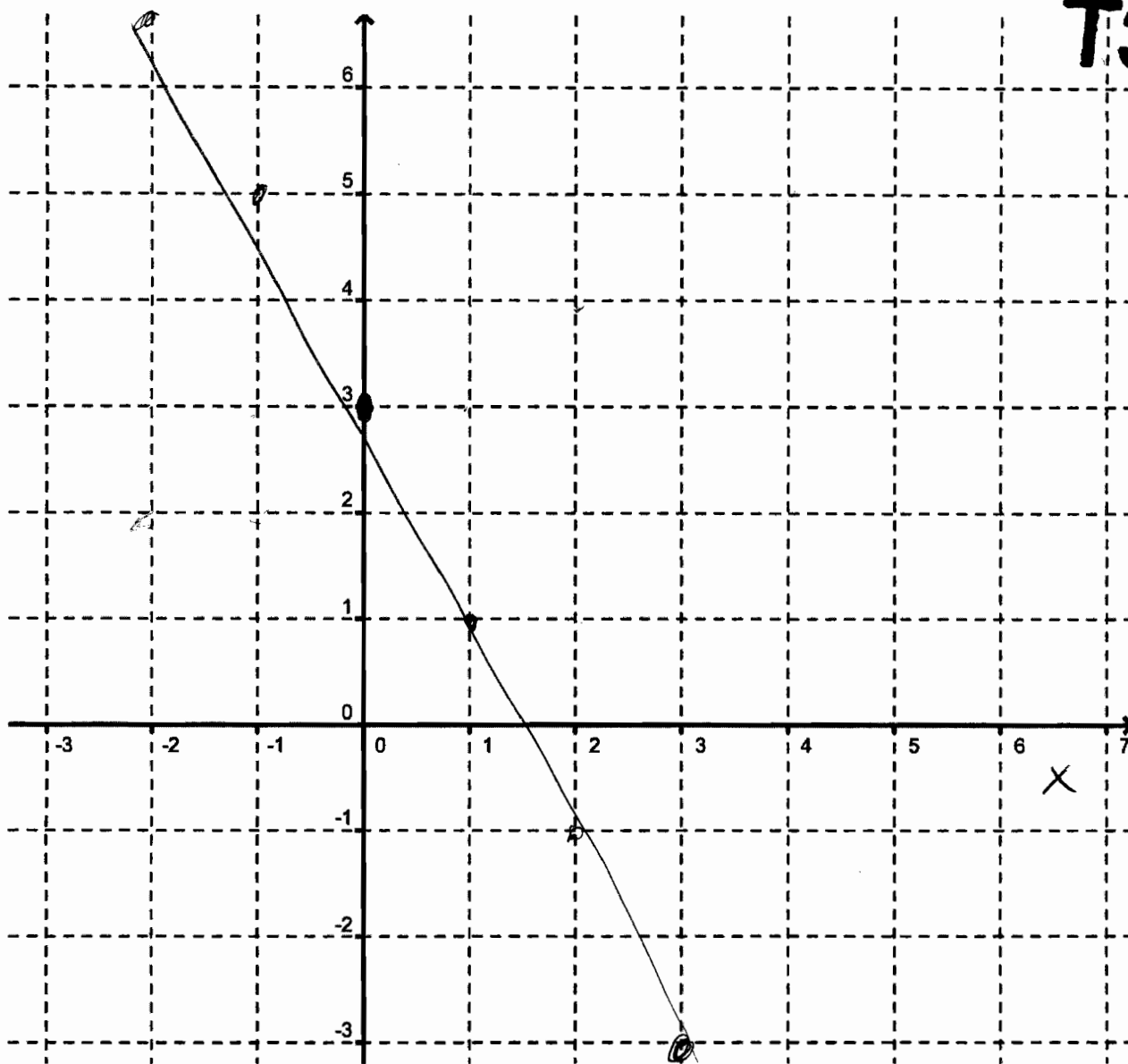

2. a. Which equation could represent the speed of someone walking steadily? $2y + x = 6$ ^x 0
 Explain your reasoning.

Because its the one above and none of them really look like it maybe $y = 3$ because its constant at 3.

b. Which equation could represent the conversion between two different monetary currencies?
 $y = \frac{1}{3}x$ ✓ 1

Linear Graphs

T4

This problem gives you the chance to:

- Show knowledge and understanding of linear graphs

Here are the equations of some linear graphs.

$$y = 3$$

$$y = 2x + 6$$

$$2y + x = 0$$

$$y = \frac{1}{3}x$$

$$2y + x = 6$$

1. Four of the graphs are drawn below.

a. Write the correct equation on each graph.

b. Draw the graph of the equation not used above on the diagram on the opposite page.

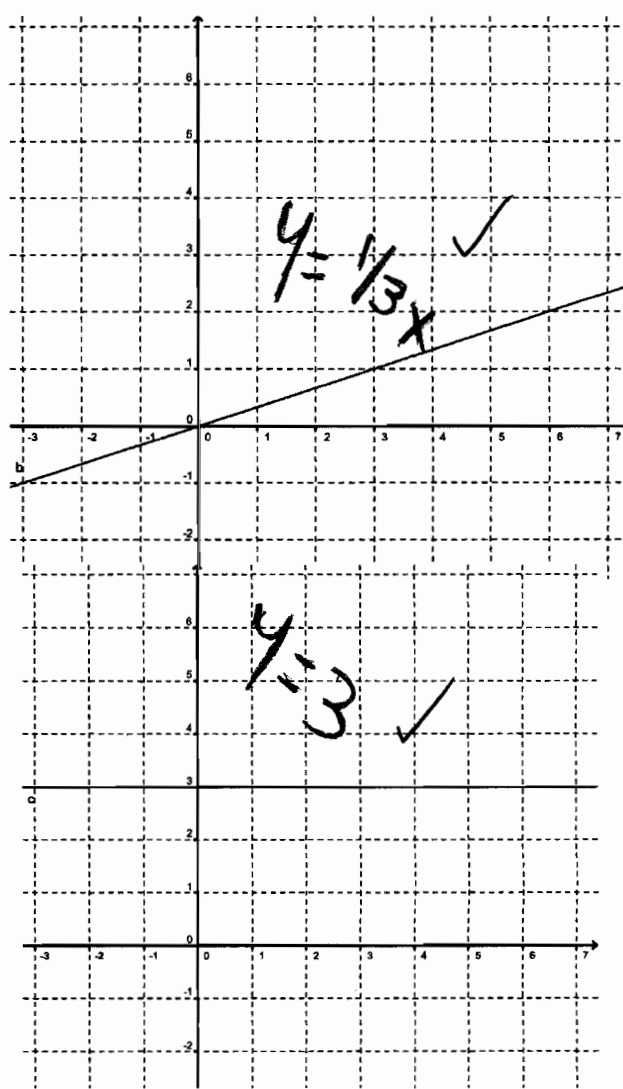
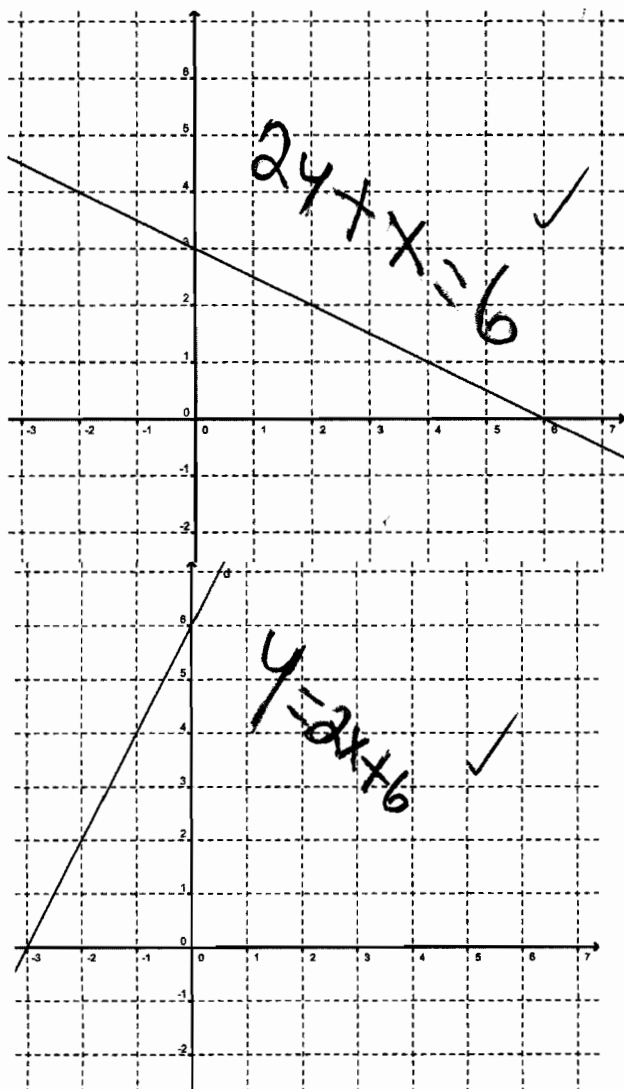

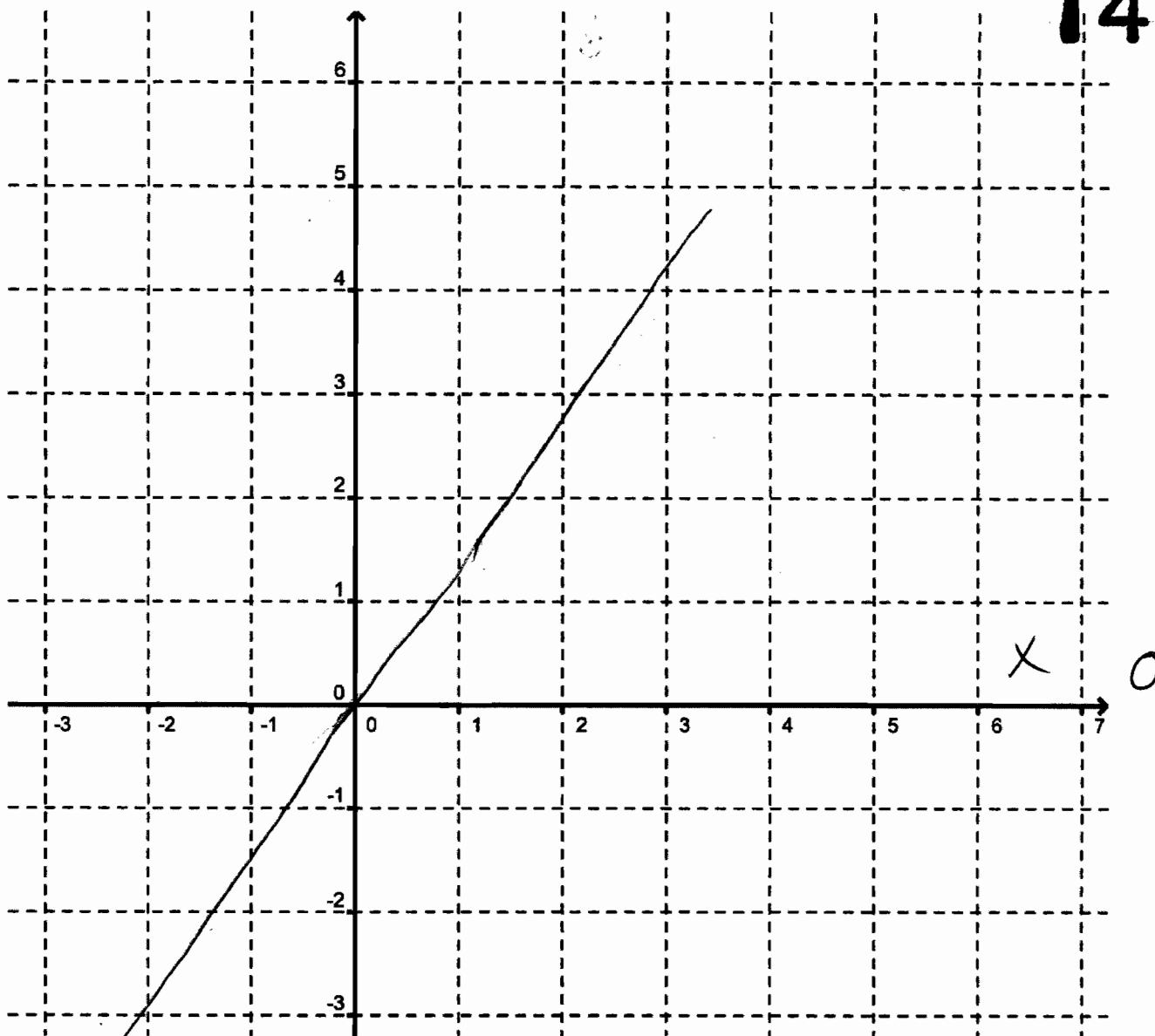

2. a. Which equation could represent the speed of someone walking steadily? $y=3$
 Explain your reasoning.

Because they are walking @ speed of 3 constantly.

b. Which equation could represent the conversion between two different monetary currencies?

$y=2x+6$

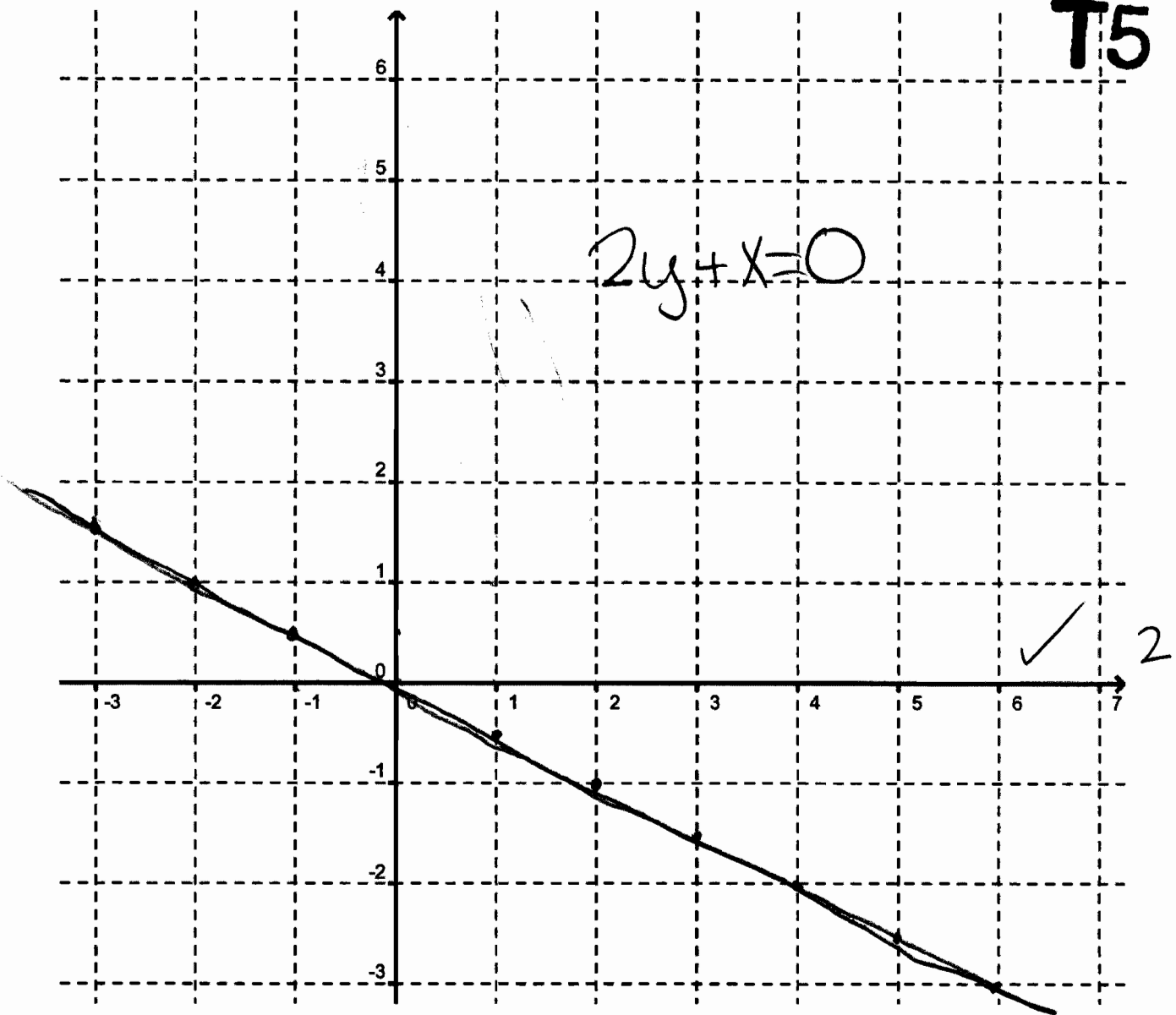

2. a. Which equation could represent the speed of someone walking steadily? $y = 2x$ \times 0
 Explain your reasoning.

because the slope doesn't change, the speed won't change
this person is walking 2 ft per sec.

b. Which equation could represent the conversion between two different monetary currencies?

$y = \frac{1}{3}x$ \checkmark 1



Linear Graphs

S1

This problem gives you the chance to:

- show knowledge and understanding of linear graphs

Here are the equations of some linear graphs.

$$y = 3$$

$$y = 2x + 6$$

$$2y + x = 0$$

$$y = \frac{1}{3}x$$

$$2y + x = 6$$

1. Four of the graphs are drawn below.
 - a. Write the correct equation on each graph.
 - b. Draw the graph of the equation not used above on the diagram on the opposite page.

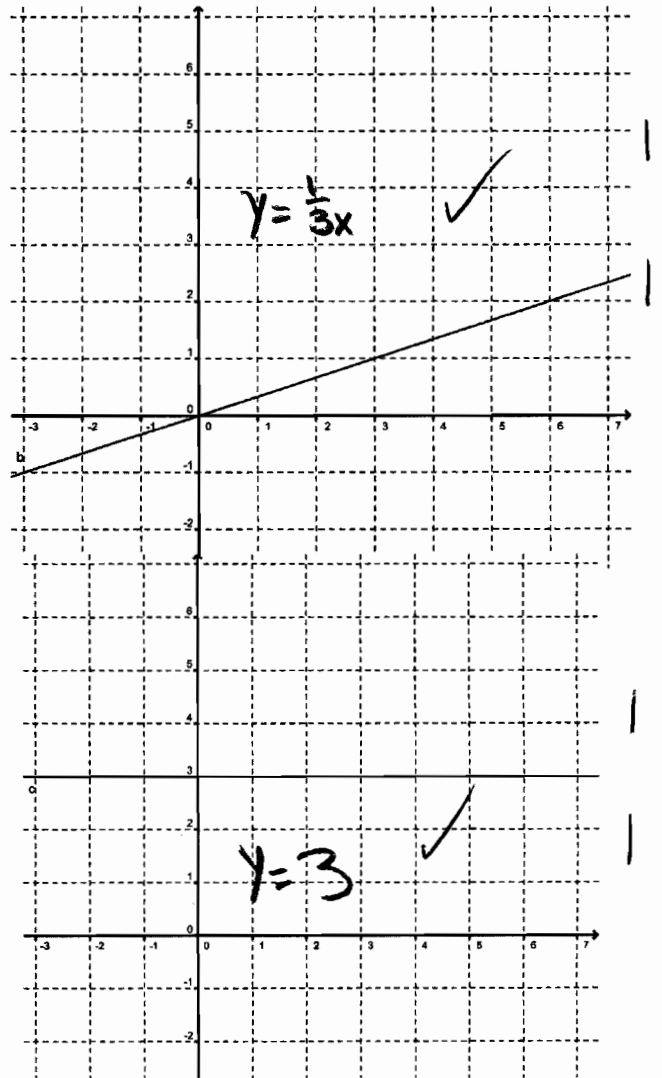
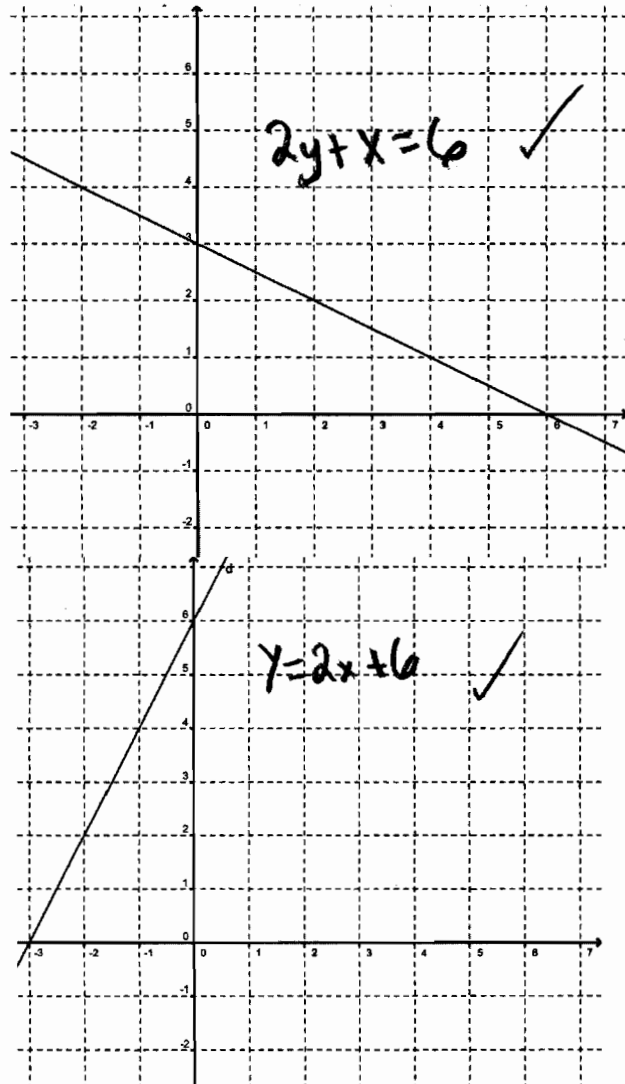

S1

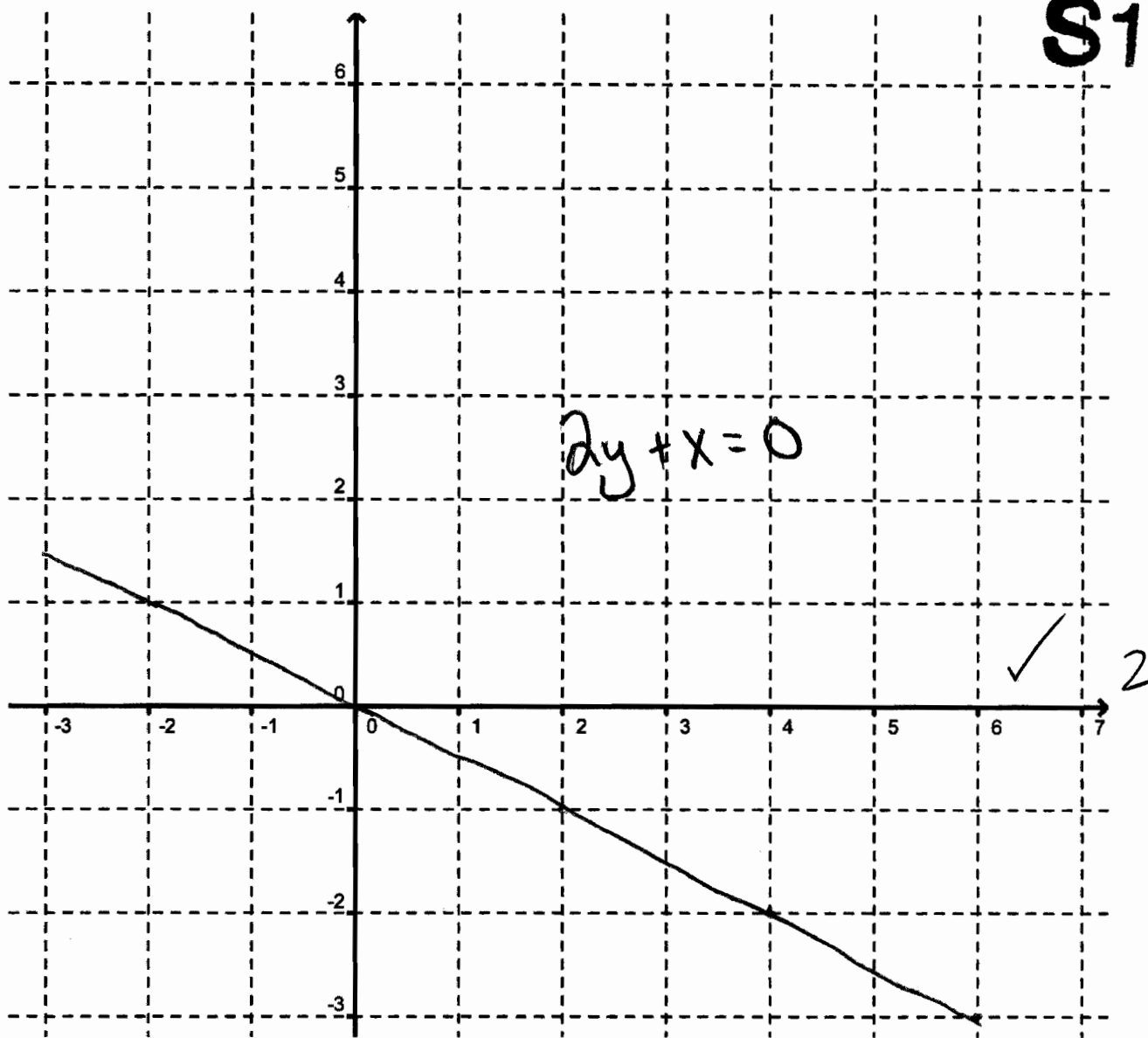

2. a. Which equation could represent the speed of someone walking steadily? $y = \frac{1}{3}x$
Explain your reasoning.

Because it is one of the only 2 positive slopes and
the other one is to sleep so you would have to run. 0
1

b. Which equation could represent the conversion between two different monetary currencies? 1
 $y = \frac{1}{3}x$ ✓

Linear Graphs

S2

This problem gives you the chance to:

- show knowledge and understanding of linear graphs

Here are the equations of some linear graphs.

$$y = 3$$

$$y = 2x + 6$$

$$2y + x = 0$$

$$y = \frac{1}{3}x$$

$$2y + x = 6$$

1. Four of the graphs are drawn below.

a. Write the correct equation on each graph.

b. Draw the graph of the equation not used above on the diagram on the opposite page.

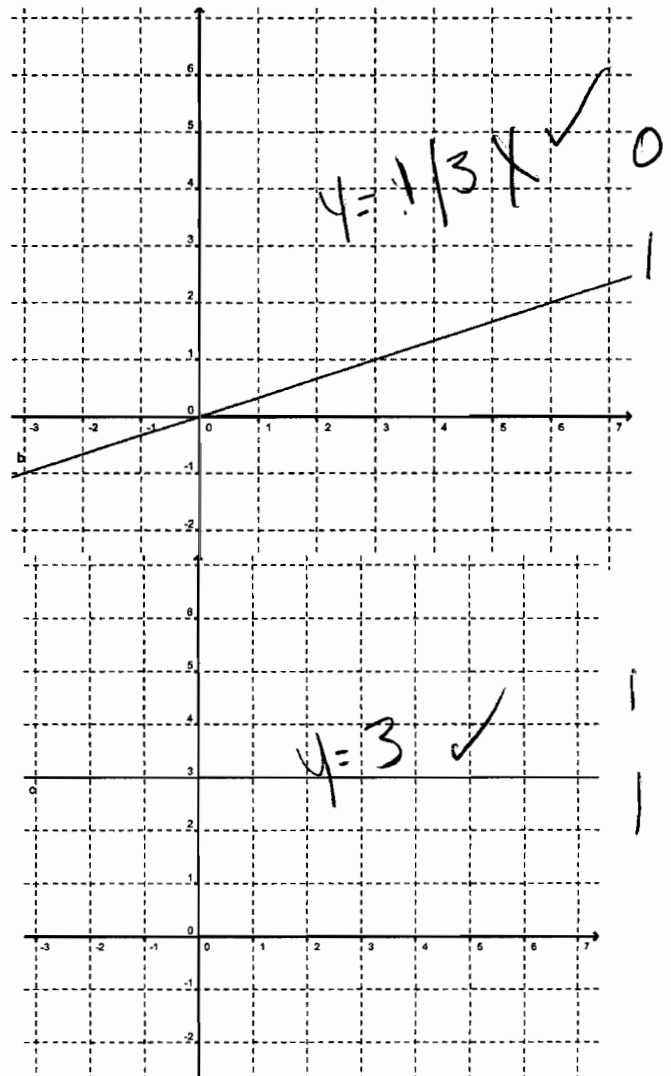
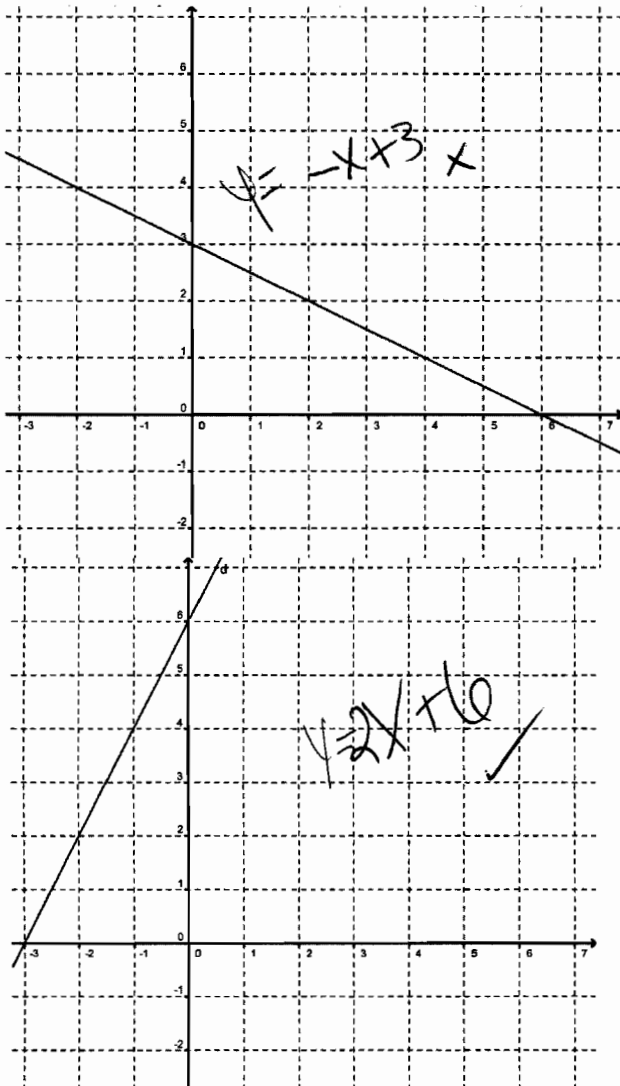

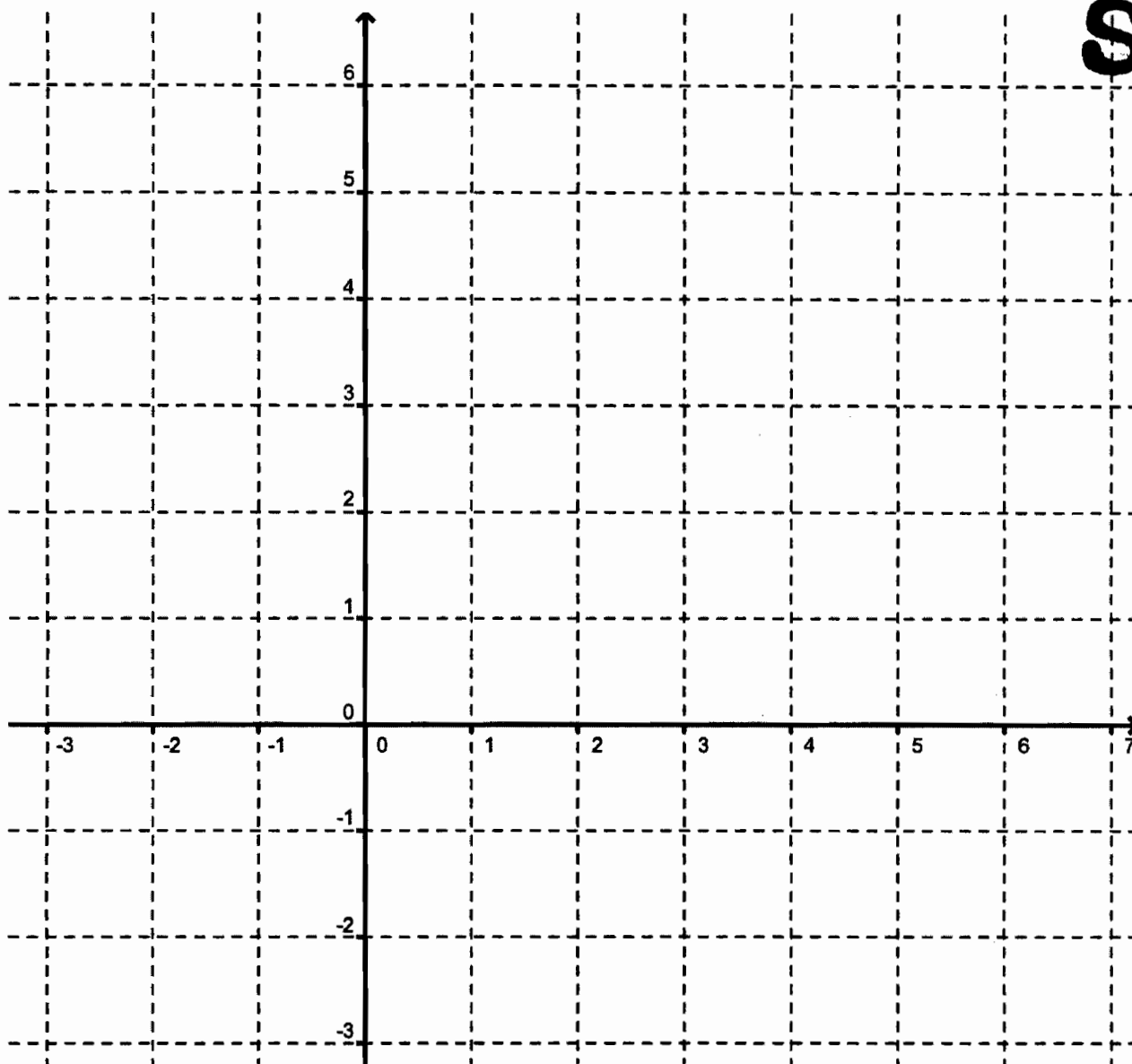

0

2. a. Which equation could represent the speed of someone walking steadily? $y=3$
 Explain your reasoning.

Because the time would be steady and the speed would be, also,

b. Which equation could represent the conversion between two different monetary currencies?

$y=-x+3$ x 0

8

Linear Graphs

S3

This problem gives you the chance to:

- show knowledge and understanding of linear graphs

$$\begin{aligned} \sqrt{y} &= 3 \\ y &= 2x + 6 \\ 2y + x &= 0 \\ y &= \frac{1}{3}x \\ 2y + x &= 6 \end{aligned}$$

$$\begin{aligned} 2y + x &= 0 \\ -x & & -x \\ \frac{2y}{2} &= \frac{0-x}{2} \\ y &= 0 - x/2 \end{aligned}$$

Here are the equations of some linear graphs.

1. Four of the graphs are drawn below.

a. Write the correct equation on each graph.

$$\begin{aligned} 2y + x &= 6 \\ -x & & -x \\ \frac{2y}{2} &= \frac{6-x}{2} \\ y &= 3 - x/2 \end{aligned}$$

b. Draw the graph of the equation not used above on the diagram on the opposite page.

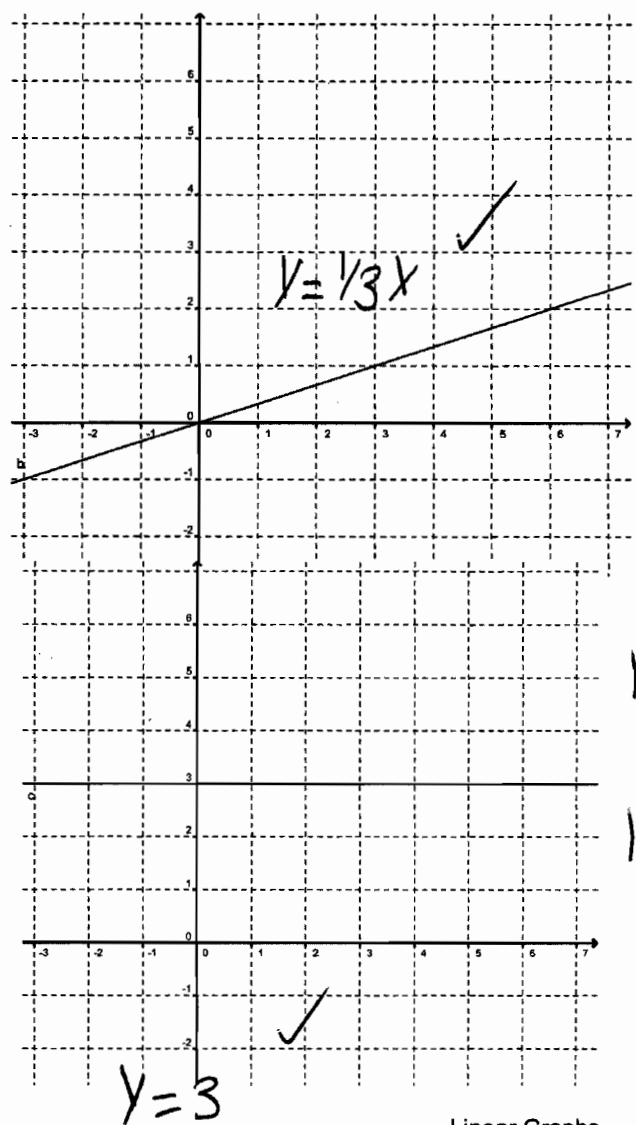
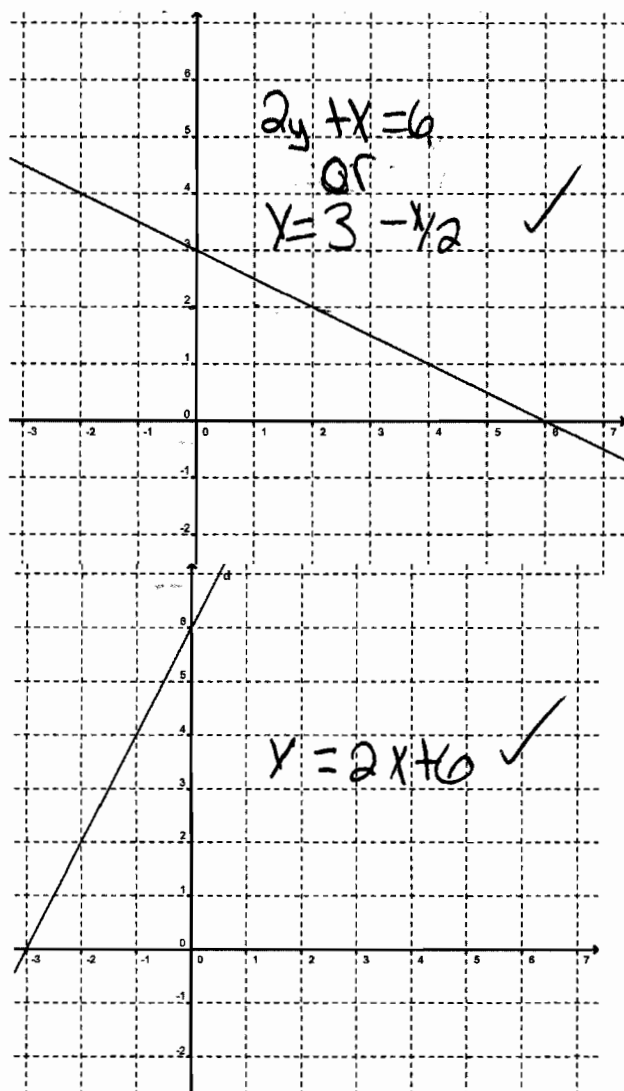

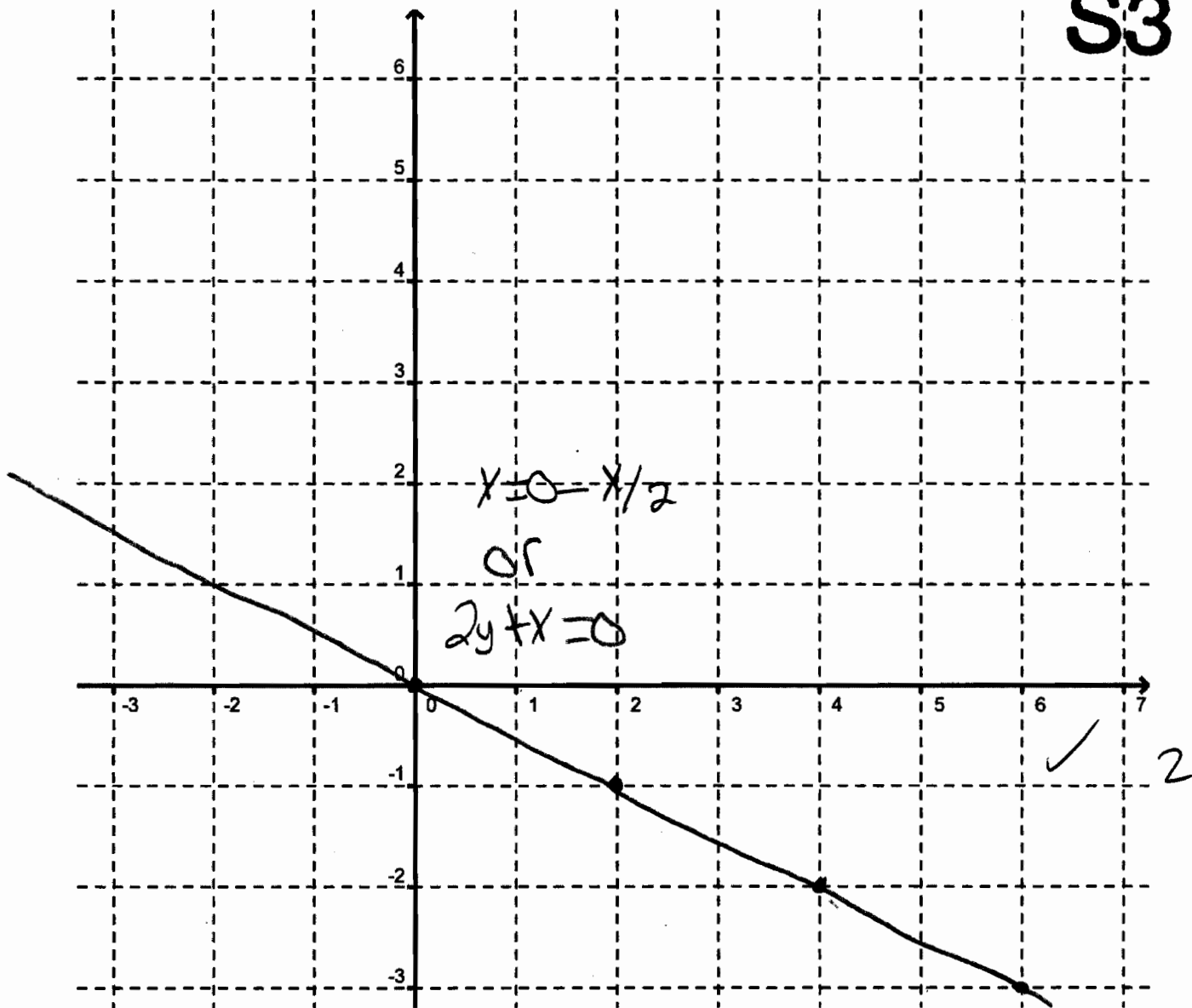

2. a. Which equation could represent the speed of someone walking steadily? $y = 3$
 Explain your reasoning.

because, it's a straight line. ^

b. Which equation could represent the conversion between two different monetary currencies?

$y = 0 - x/2$ x

Linear Graphs

S4

This problem gives you the chance to:

- show knowledge and understanding of linear graphs

Here are the equations of some linear graphs.

$$\begin{aligned}y &= 3 \\y &= 2x + 6 \\2y + x &= 0 \\y &= \frac{1}{3}x \\2y + x &= 6\end{aligned}$$

1. Four of the graphs are drawn below.
 - a. Write the correct equation on each graph.
 - b. Draw the graph of the equation not used above on the diagram on the opposite page.

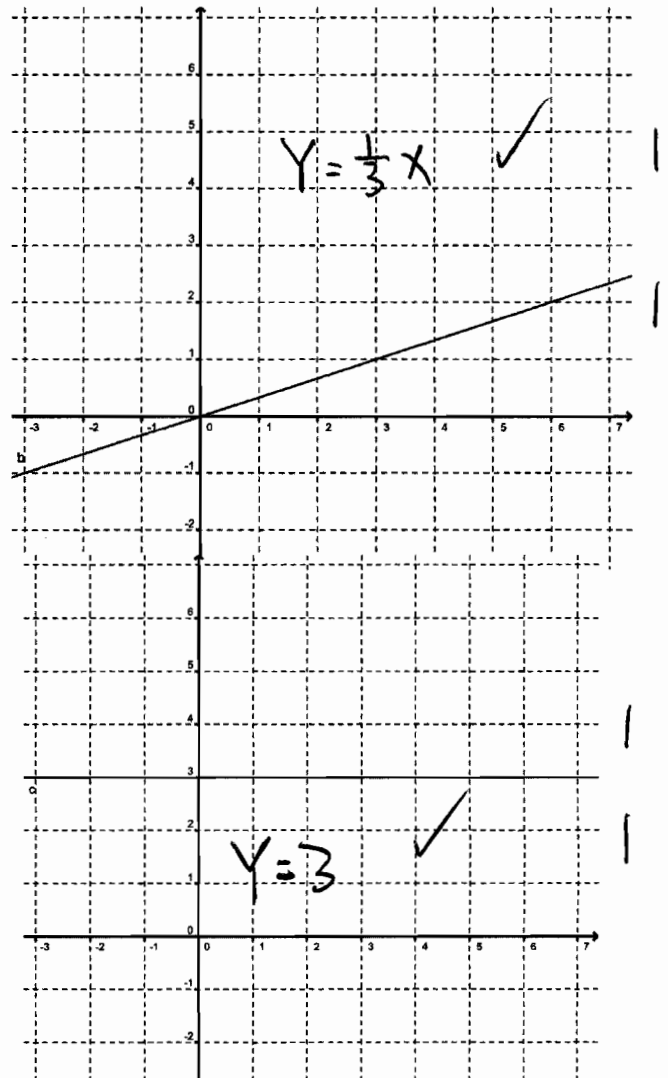
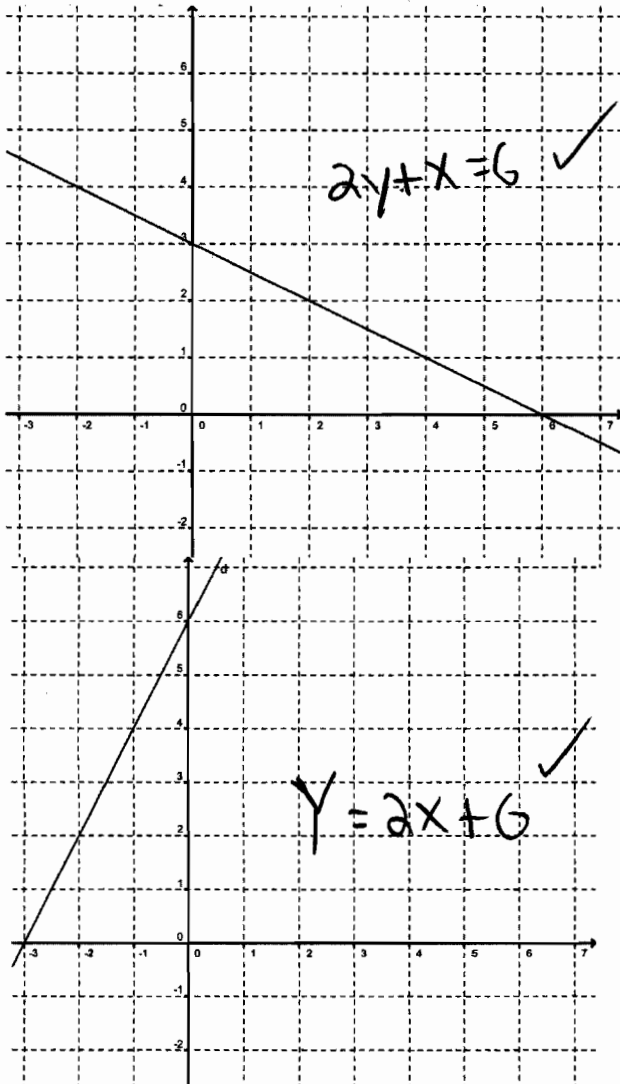

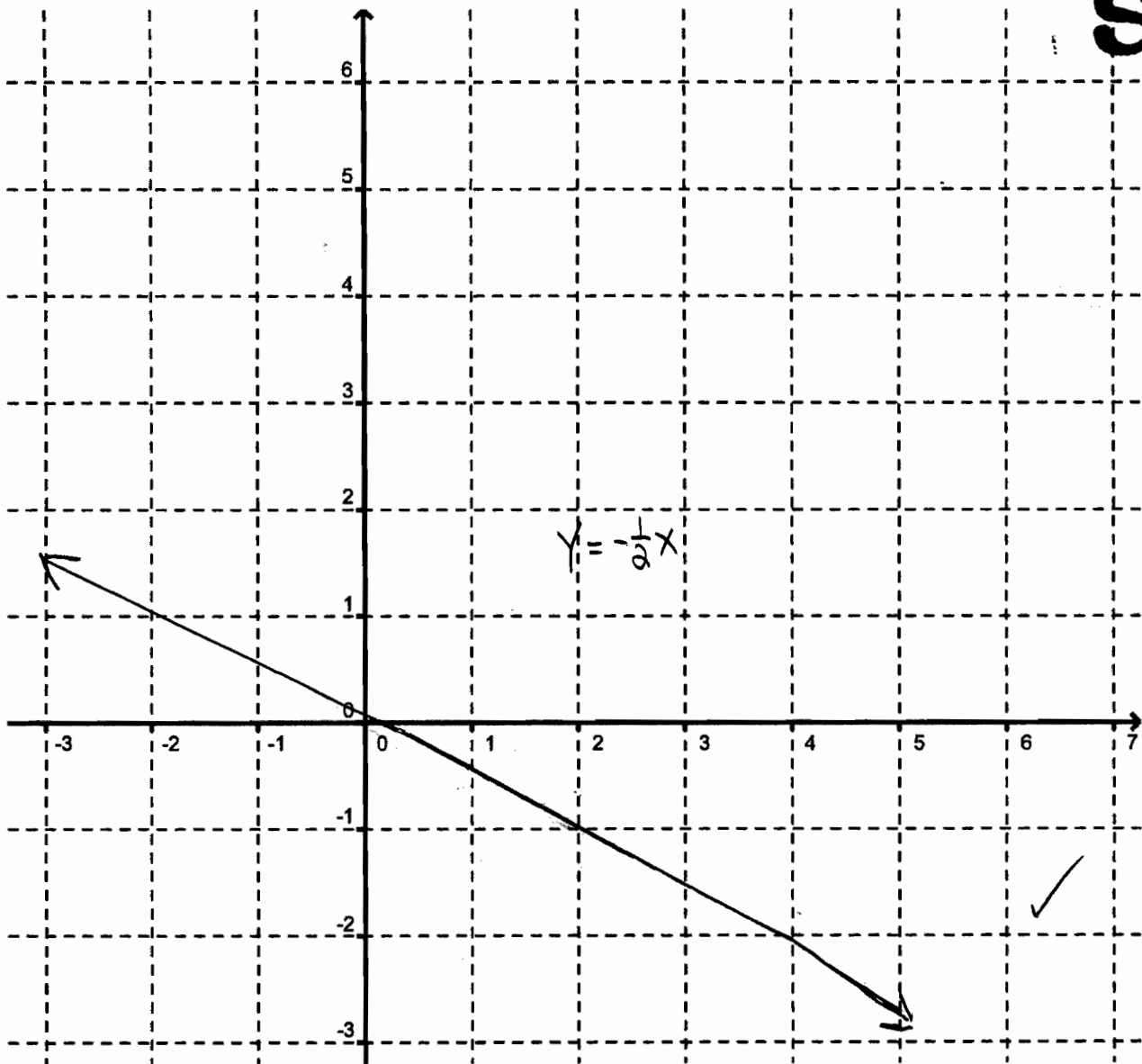

2. a. Which equation could represent the speed of someone walking steadily? $Y=3$ because
 Explain your reasoning.

X could be time while Y is speed. ✓ 1

b. Which equation could represent the conversion between two different monetary currencies?

$Y = \frac{1}{3}X$ ✓ 1

Linear Graphs

S5

This problem gives you the chance to:

- show knowledge and understanding of linear graphs

Here are the equations of some linear graphs.

~~$y=3$~~
 ~~$y=2x+6$~~
 $2y+x=0$
 ~~$y=\frac{1}{3}x$~~
 ~~$2y+x=6$~~

$2y+x=0$
 $-x$
 $2y=0-x$
 $\frac{2y}{2}=0-x$

1. Four of the graphs are drawn below.
 - a. Write the correct equation on each graph.
 - b. Draw the graph of the equation not used above on the diagram on the opposite page.

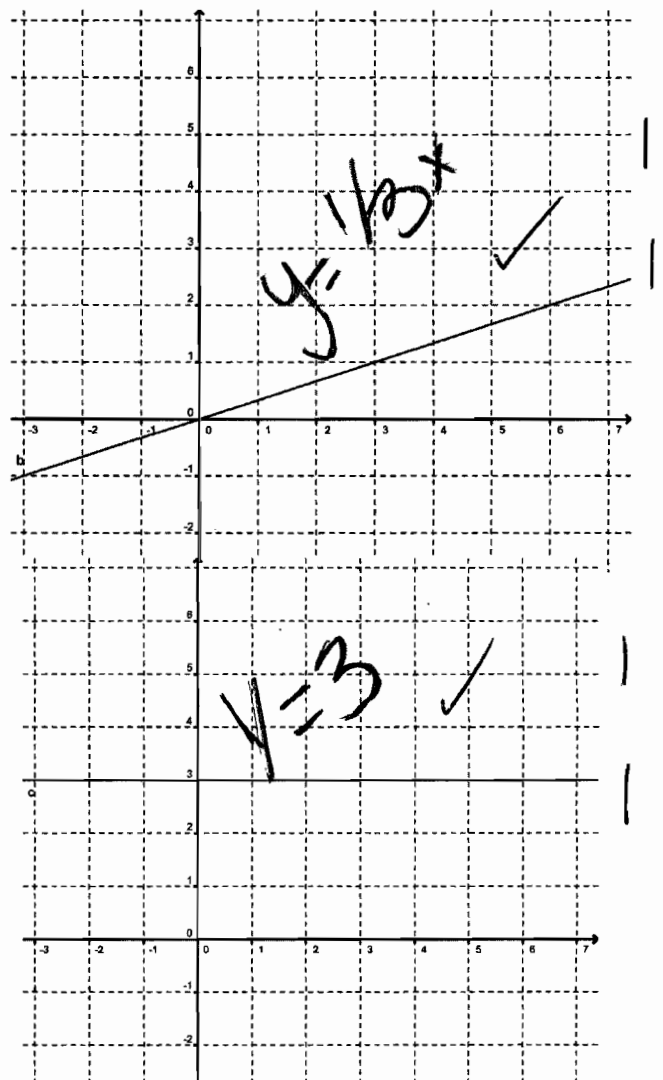
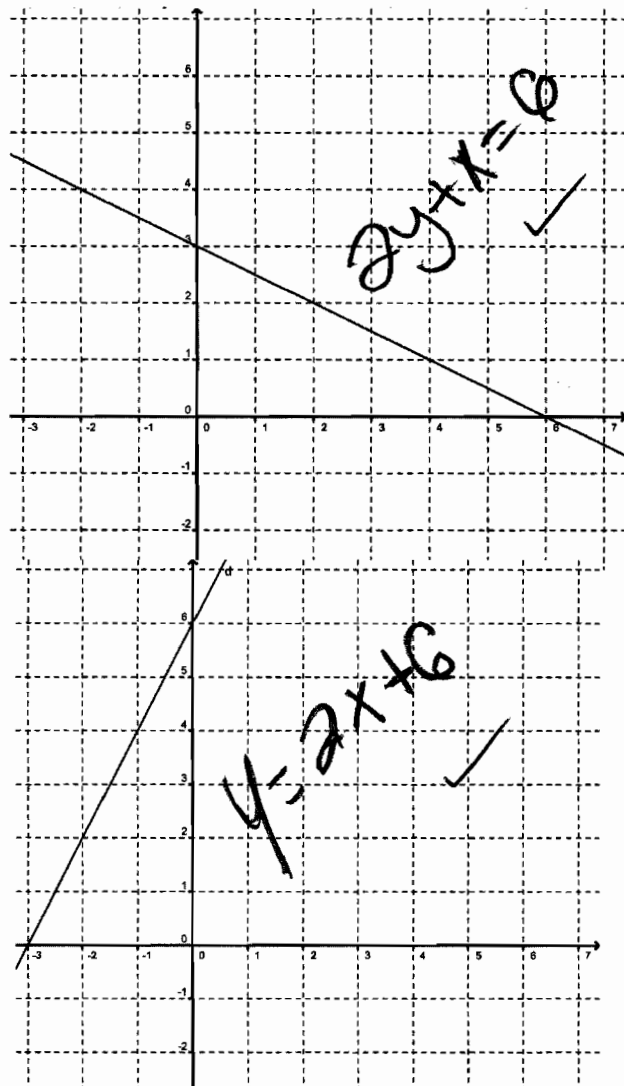

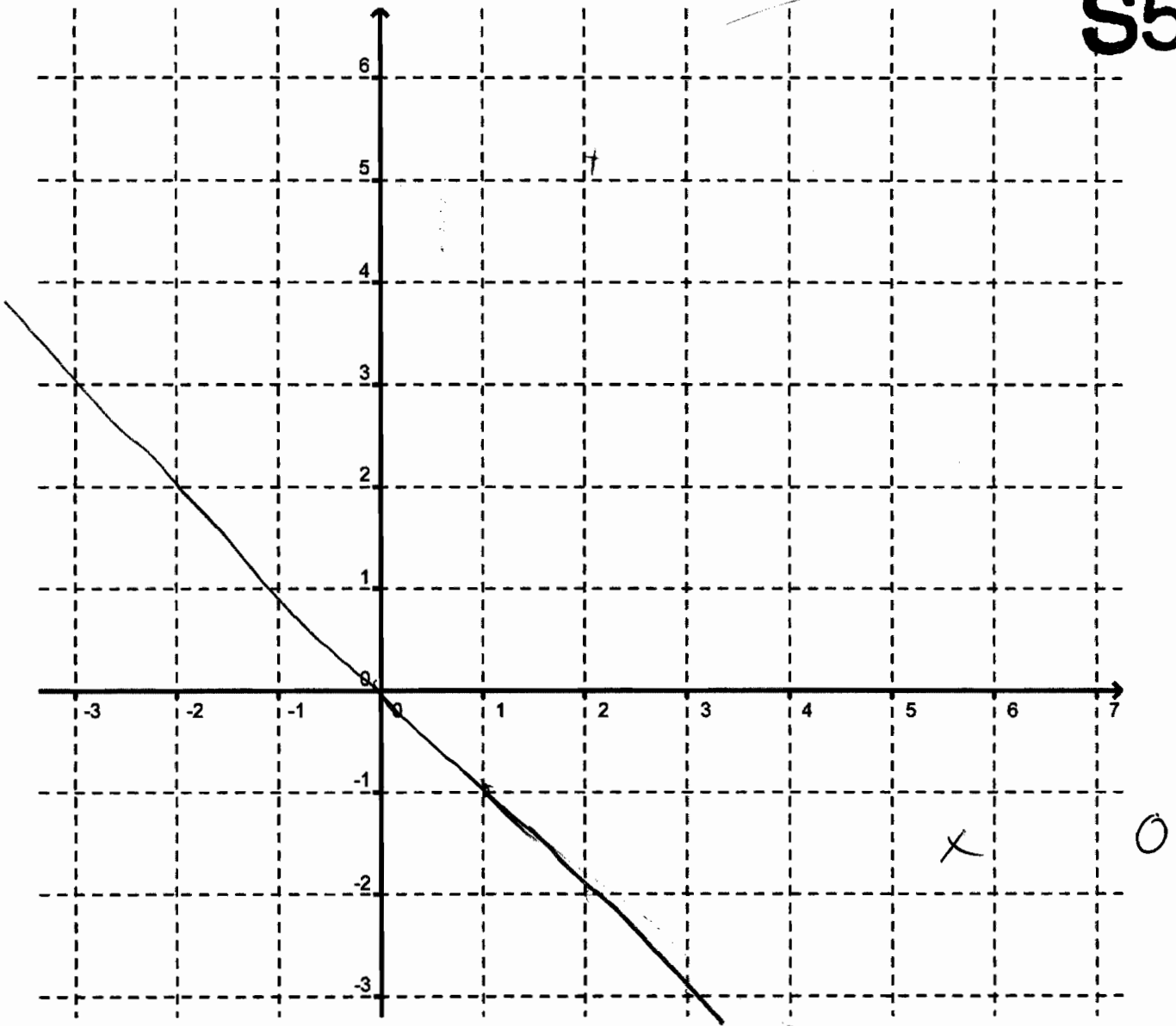

2. a. Which equation could represent the speed of someone walking steadily? _____
 Explain your reasoning.

$y = \frac{1}{3}x$, because It's the only graph that would make sense to rise!!! 0

b. Which equation could represent the conversion between two different monetary currencies?

$y = \frac{1}{3}x$ ✓ 1



Linear Graphs

S6

This problem gives you the chance to:

- show knowledge and understanding of linear graphs

Here are the equations of some linear graphs.

$$y = 3$$

$$y = 2x + 6$$

$$2y + x = 0$$

$$y = \frac{1}{3}x$$

$$2y + x = 6$$

1. Four of the graphs are drawn below.

a. Write the correct equation on each graph.

b. Draw the graph of the equation not used above on the diagram on the opposite page.

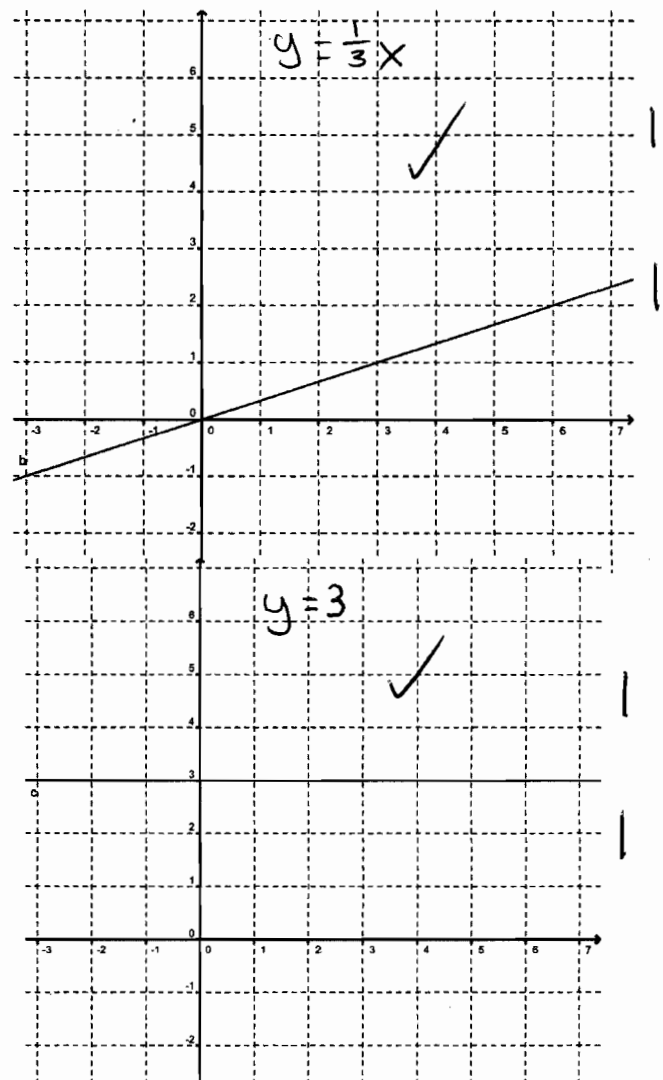
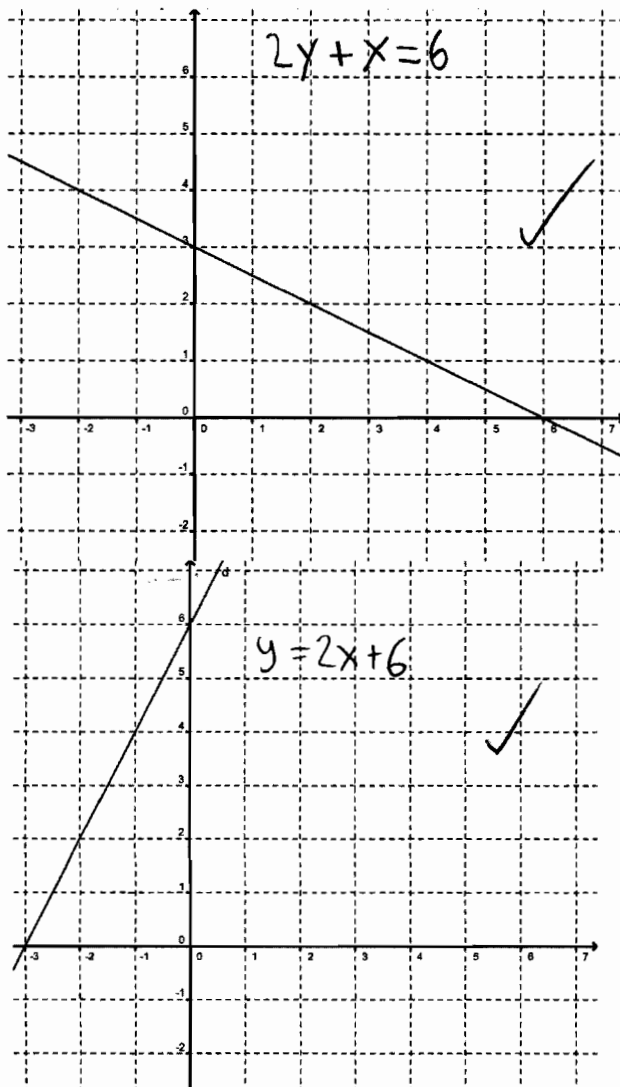

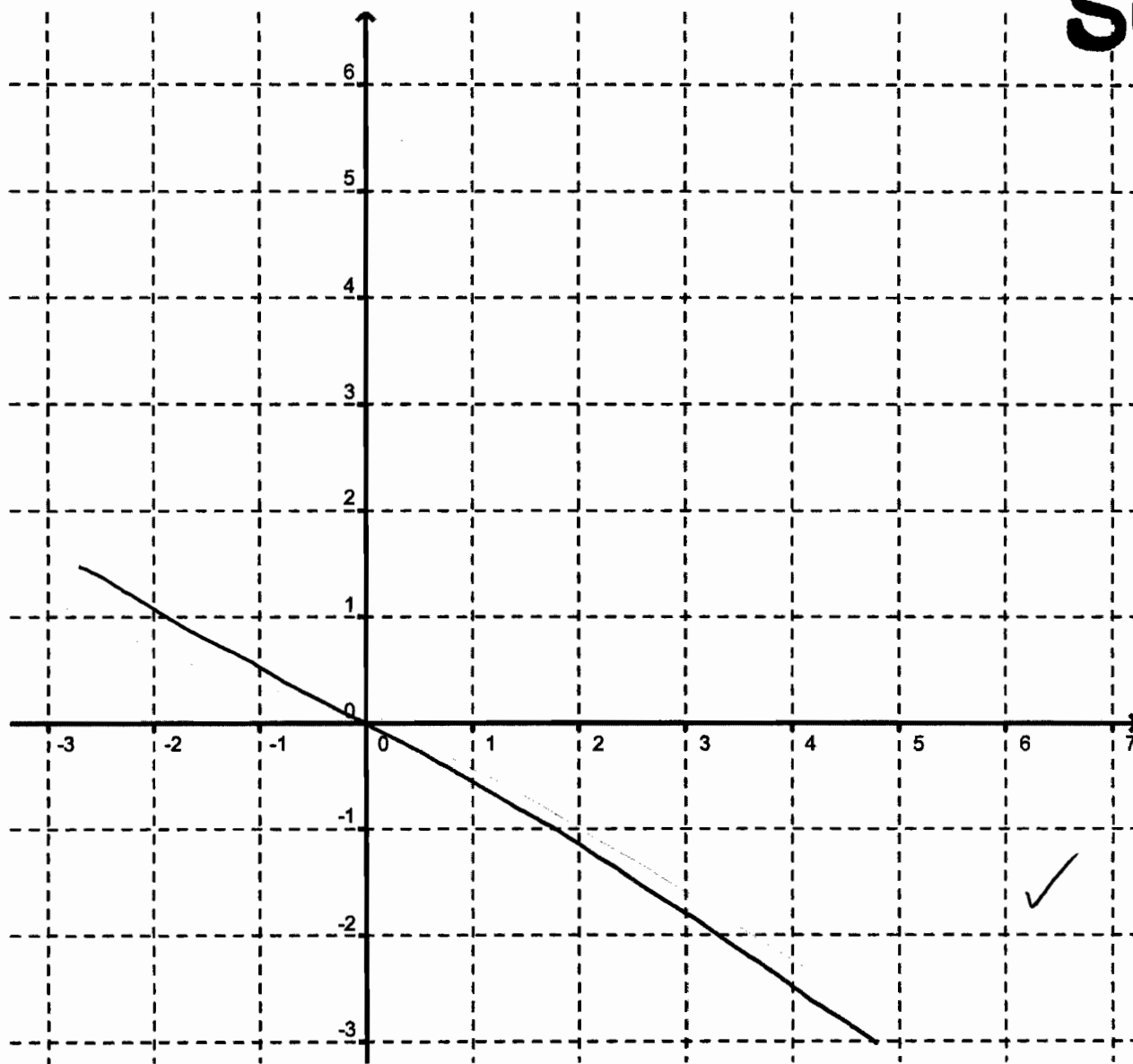

2. a. Which equation could represent the speed of someone walking steadily? $y=3$
 Explain your reasoning.

they could be walking in a straight line. 1 0

b. Which equation could represent the conversion between two different monetary currencies? $y=\frac{1}{3}x$ ✓ 1

Linear Graphs

S7

This problem gives you the chance to:

- Show knowledge and understanding of linear graphs

Here are the equations of some linear graphs.

$$\begin{aligned}
 & y = 3 \\
 & y = 2x + 6 \\
 & \frac{2y + x = 0}{2} \quad y + x = 0 \\
 & y = \frac{1}{3}x \\
 & \frac{2y + x = 6}{2} \quad y + x = 3 - x
 \end{aligned}$$

- Four of the graphs are drawn below.
 - Write the correct equation on each graph.
 - Draw the graph of the equation not used above on the diagram on the opposite page.

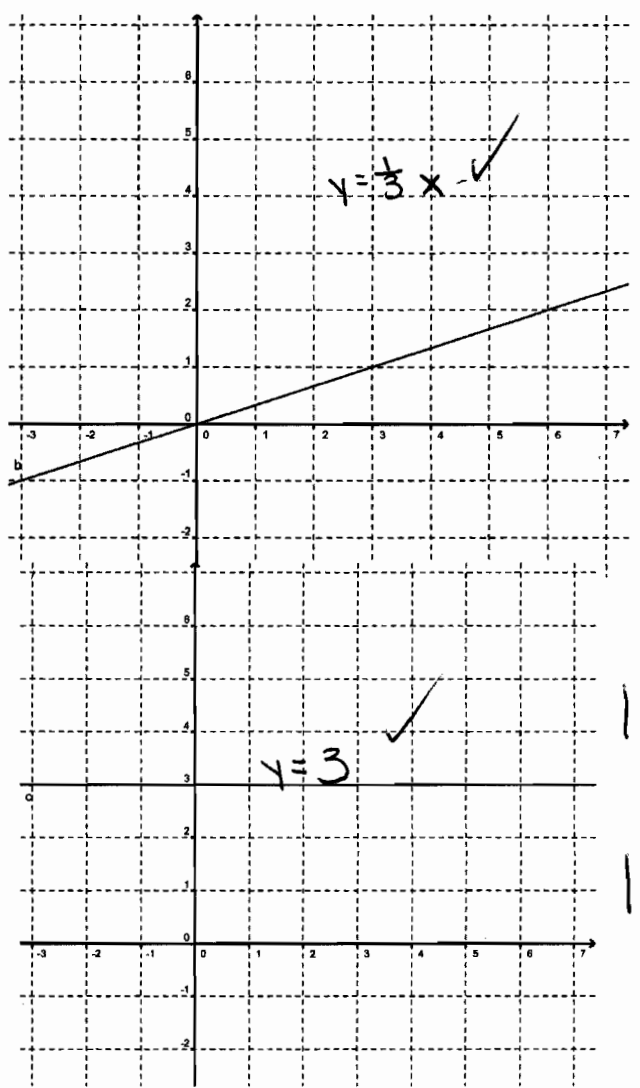
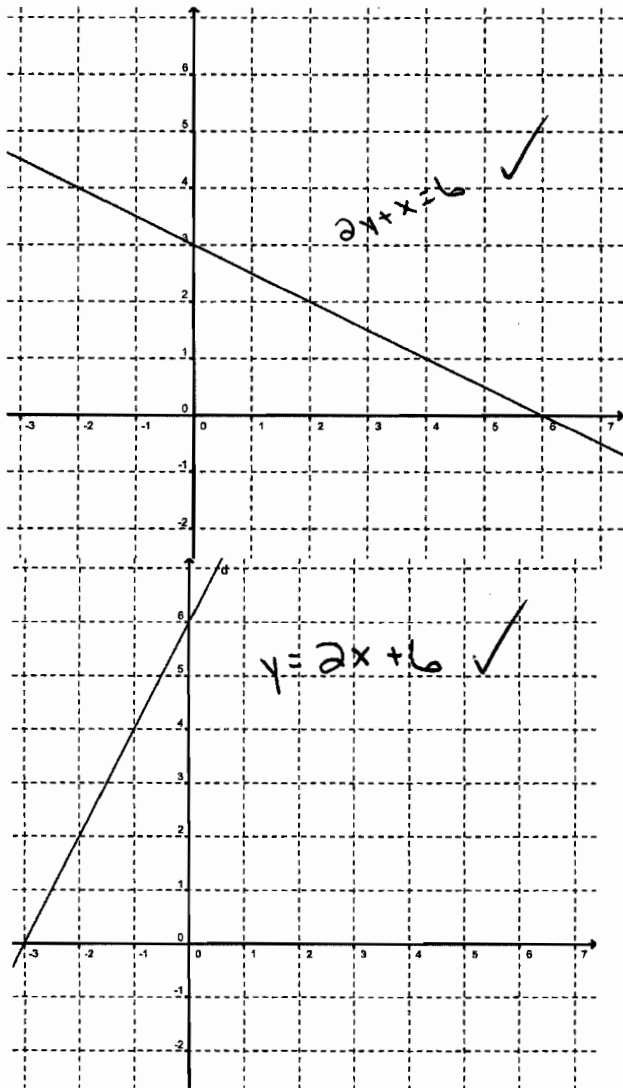

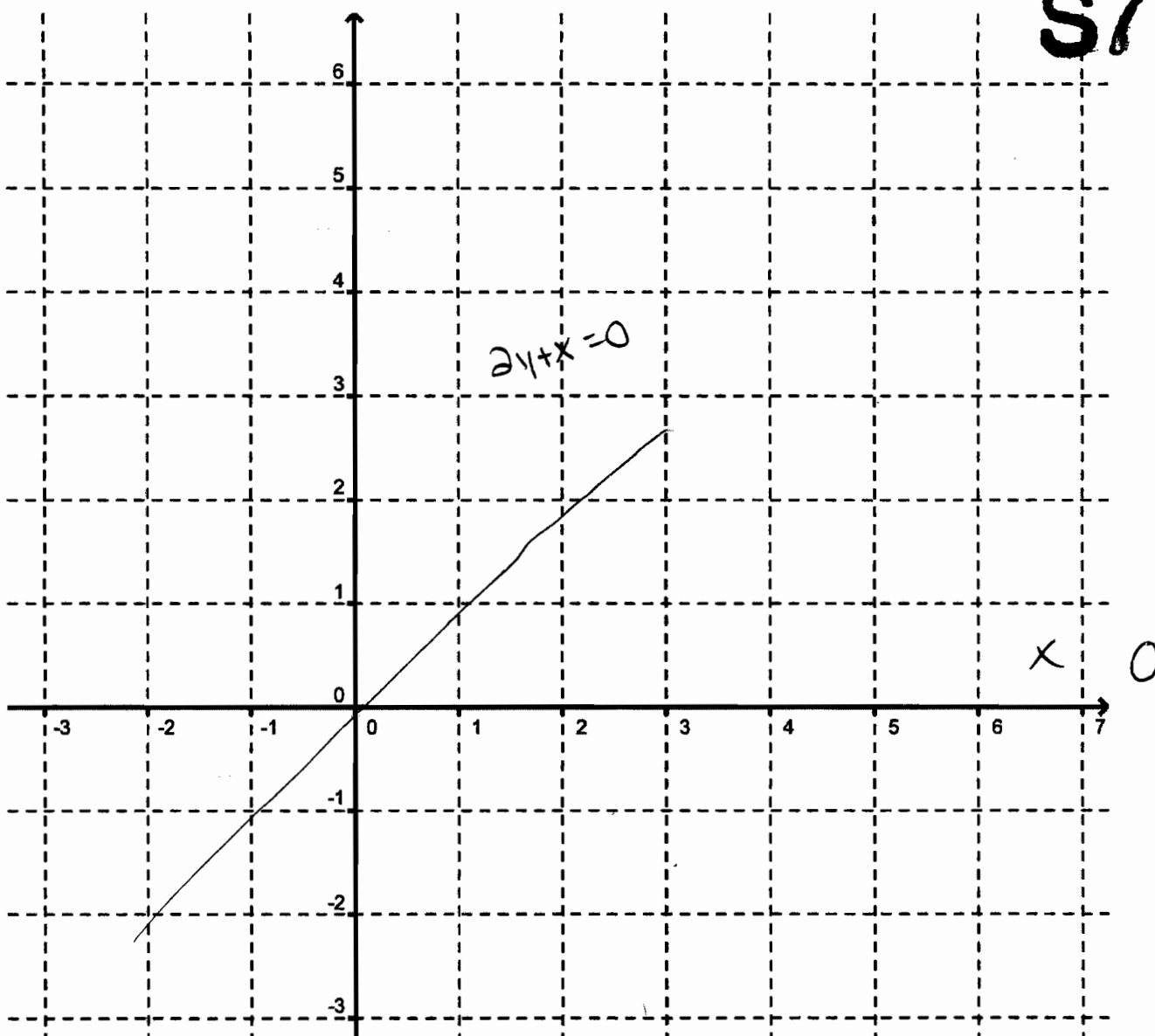

2. a. Which equation could represent the speed of someone walking steadily? $y = 3$
 Explain your reasoning.

because, speed stays the same, but your
still moving (distance) ✓

b. Which equation could represent the conversion between two different monetary currencies?

$y = \frac{1}{3}x$ ✓

Linear Graphs

S8

This problem gives you the chance to:

- show knowledge and understanding of linear graphs

Here are the equations of some linear graphs.

$$y = 3$$

$$y = 2x + 6$$

$$2y + x = 0$$

$$y = \frac{1}{3}x$$

$$2y + x = 6$$

$$2y = \frac{-x}{2}$$

$$y = \frac{-x}{2}$$

$$\frac{2y}{2} = \frac{6-x}{2}$$

$$y = 3 - x$$

1. Four of the graphs are drawn below.

a. Write the correct equation on each graph.

b. Draw the graph of the equation not used above on the diagram on the opposite page.

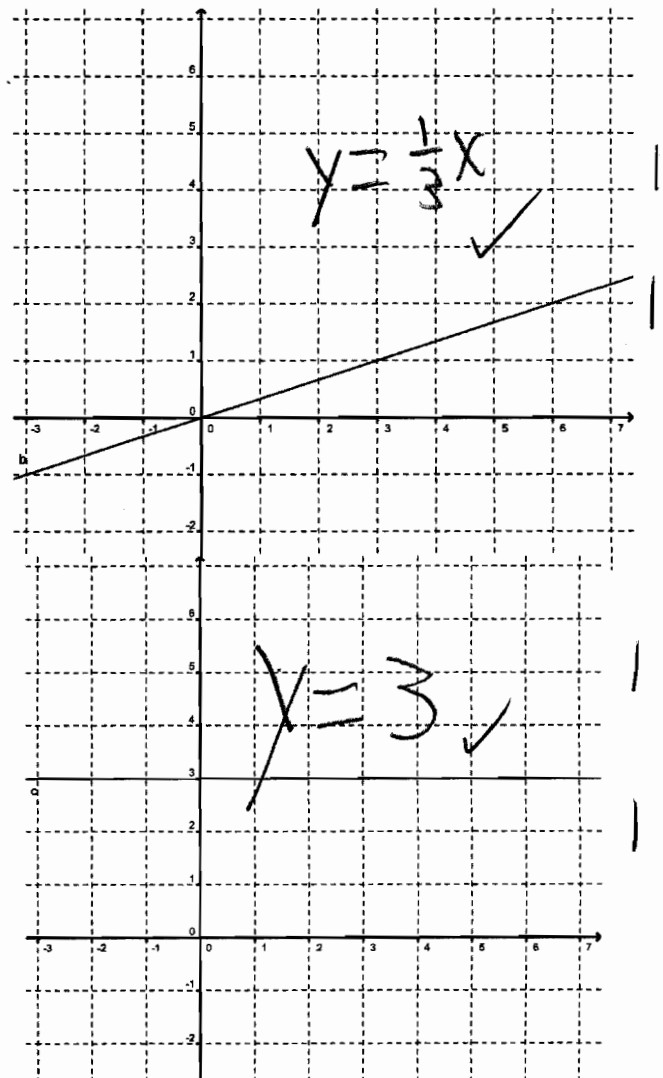
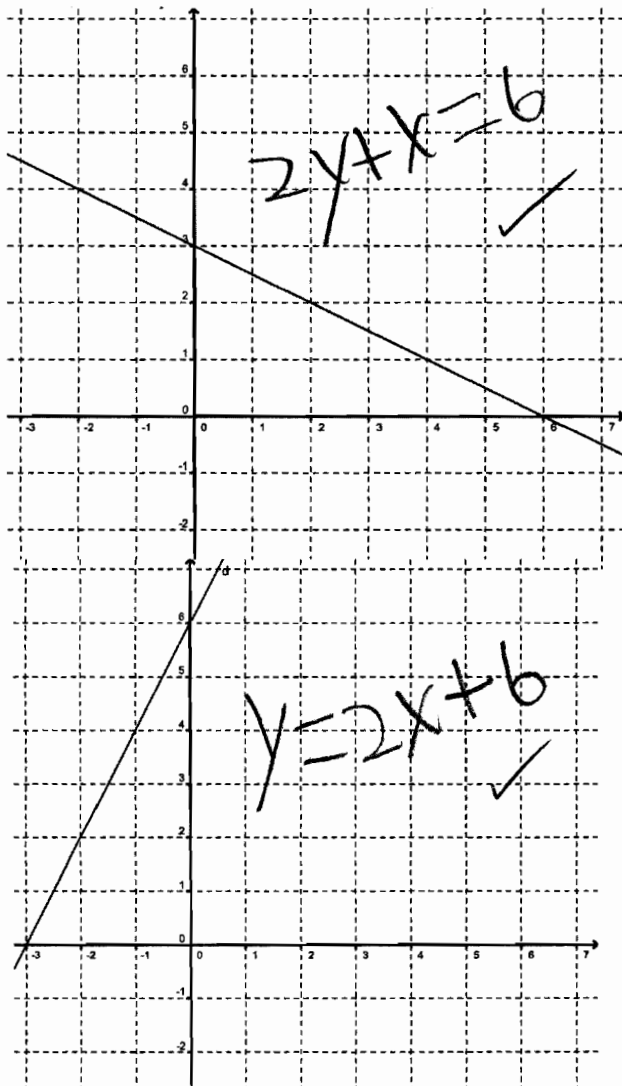

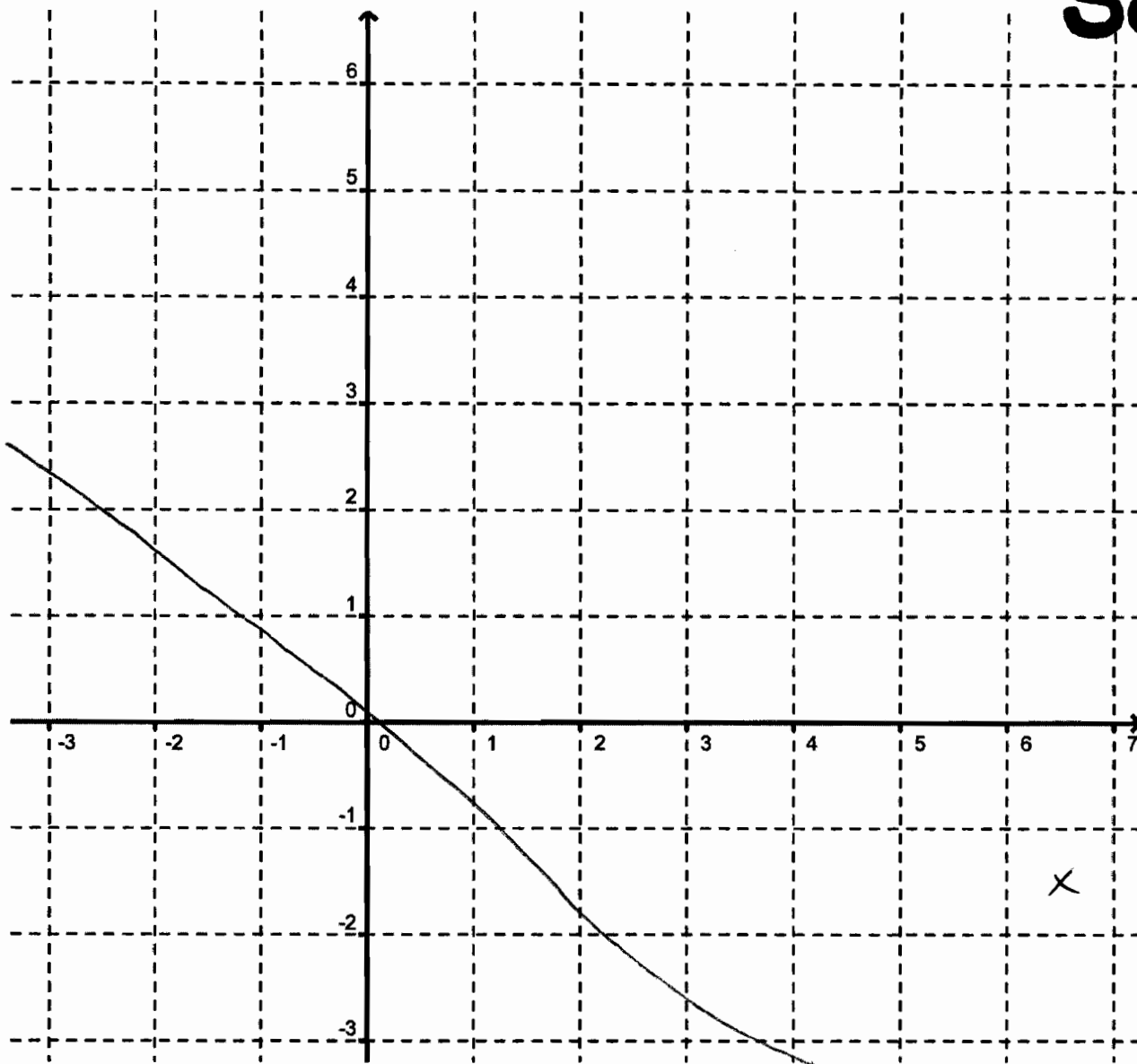

2. a. Which equation could represent the speed of someone walking steadily? $y = x$ ^x ₀
 Explain your reasoning.

because $y = x$ is a steady rate that's
not too fast

b. Which equation could represent the conversion between two different monetary currencies?
 x^2 ^x ₀

8

4

Linear Graphs

S9

This problem gives you the chance to:

- show knowledge and understanding of linear graphs

Here are the equations of some linear graphs.

$$y = 3$$

$$y = 2x + 6$$

$$2y + x = 0$$

$$y = \frac{1}{3}x$$

$$2y + x = 6$$

$$2y + x = 0$$

$$-x = -2y$$

$$\frac{2y}{2} = \frac{0-x}{2}$$

$$y = x/2$$

$$2y + x = 6$$

$$2y = 6 - x$$

$$y = 3 - x/2$$

1. Four of the graphs are drawn below.

a. Write the correct equation on each graph.

b. Draw the graph of the equation not used above on the diagram on the opposite page.

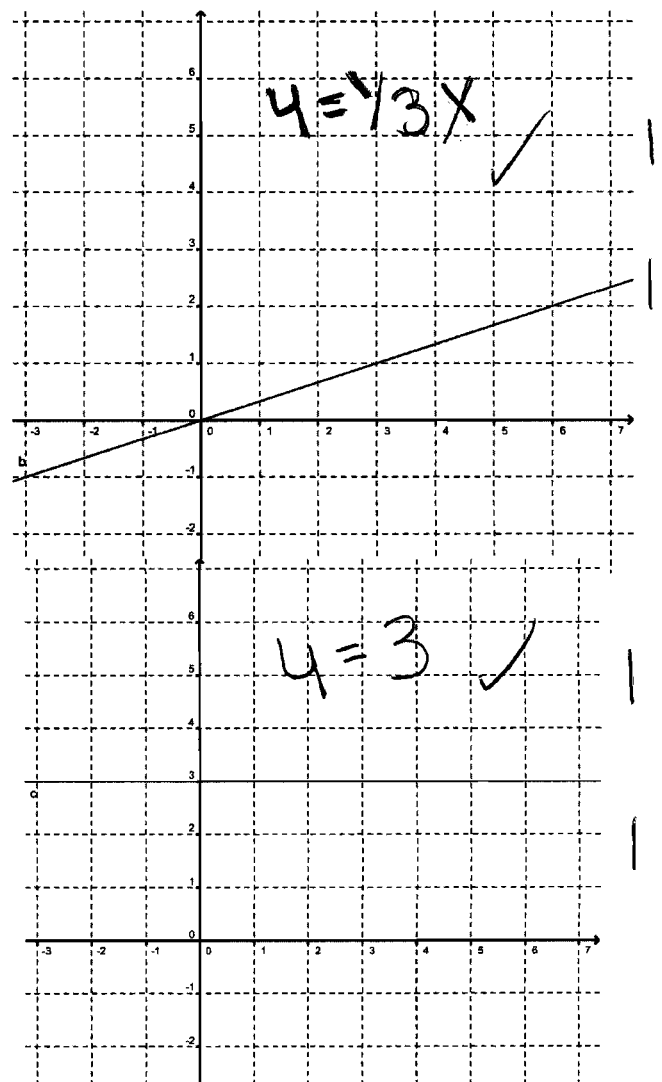
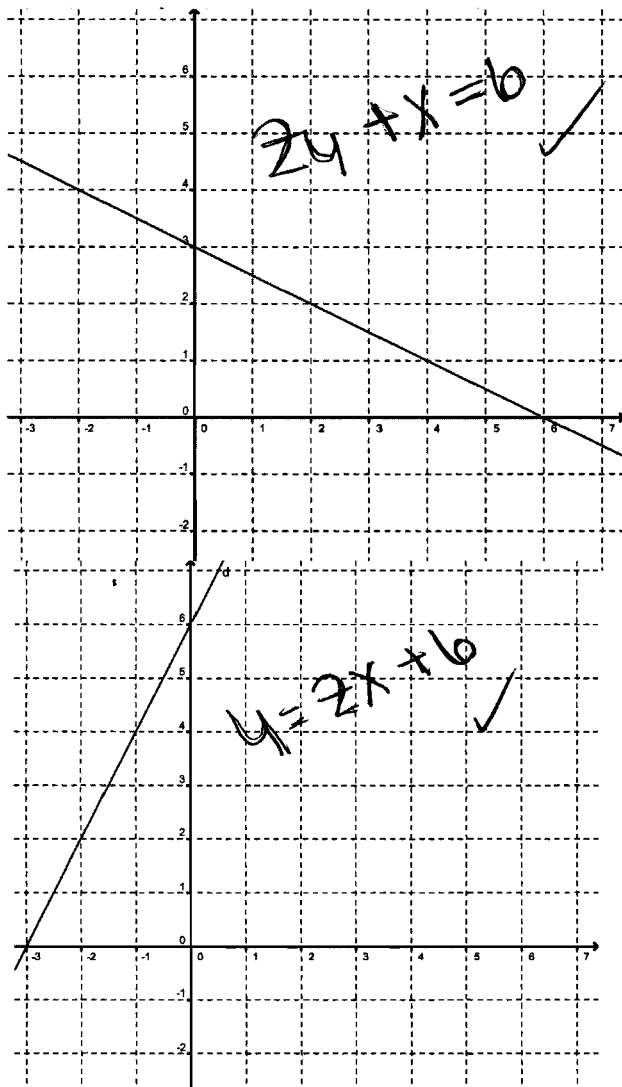

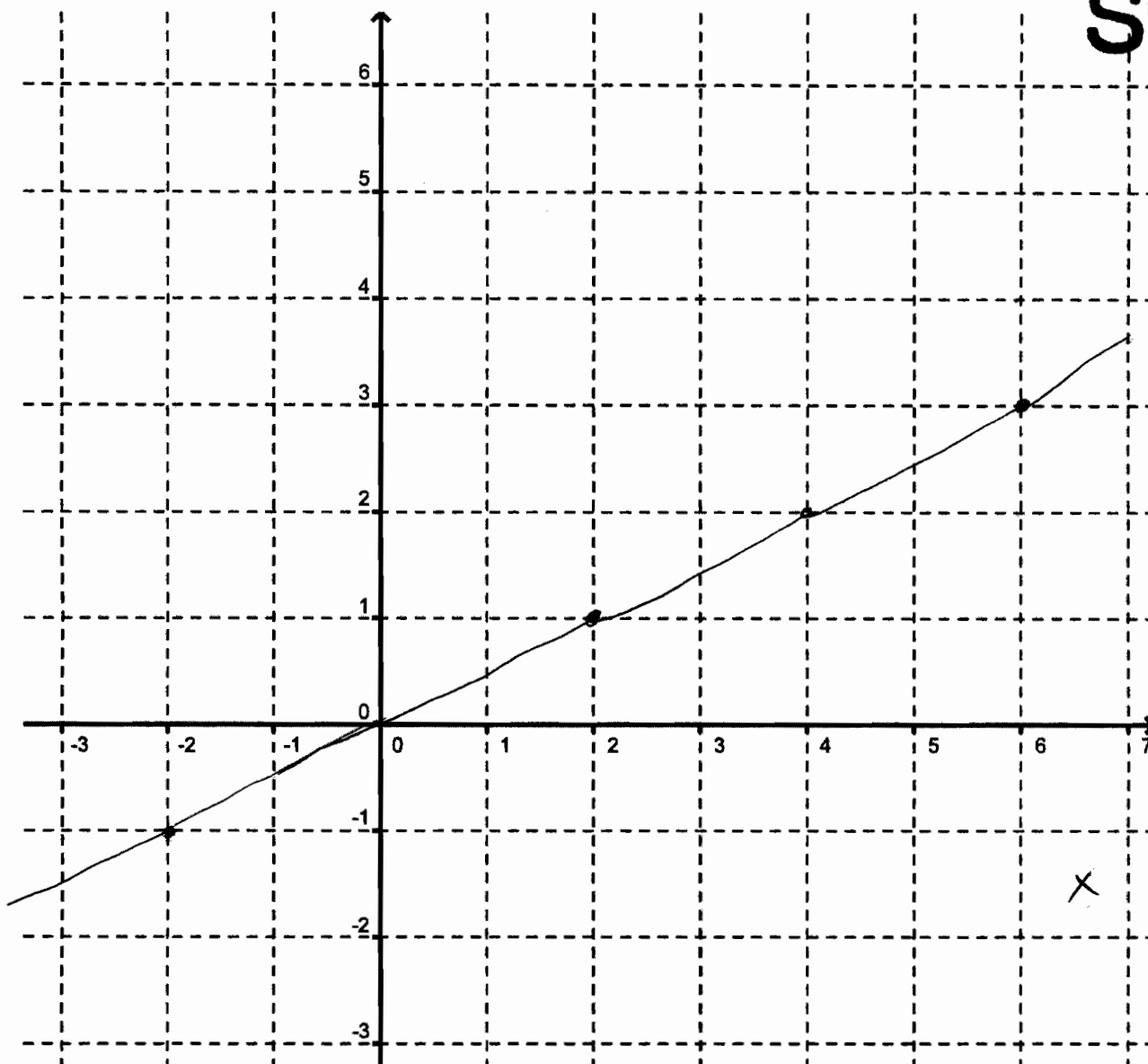

2. a. Which equation could represent the speed of someone walking steadily? $y = 3$
 Explain your reasoning.

Because they are walking at 0
 the same pace and not walking
 up a steep hill or mountain. x

b. Which equation could represent the conversion between two different monetary currencies?

$y = 1/3 x$ ✓

8

Linear Graphs

S10

This problem gives you the chance to:

- show knowledge and understanding of linear graphs

Here are the equations of some linear graphs.

$$y = 3$$

$$y = 2x + 6$$

$$2y + x = 0$$

$$y = \frac{1}{3}x$$

$$2y + x = 6$$

slope 2
 $y = -\frac{1}{2}x$ slope $-\frac{1}{2}$ →

$y = -\frac{1}{2}x + 3$ slope $-\frac{1}{2}$

1. Four of the graphs are drawn below.

a. Write the correct equation on each graph.

b. Draw the graph of the equation not used above on the diagram on the opposite page.

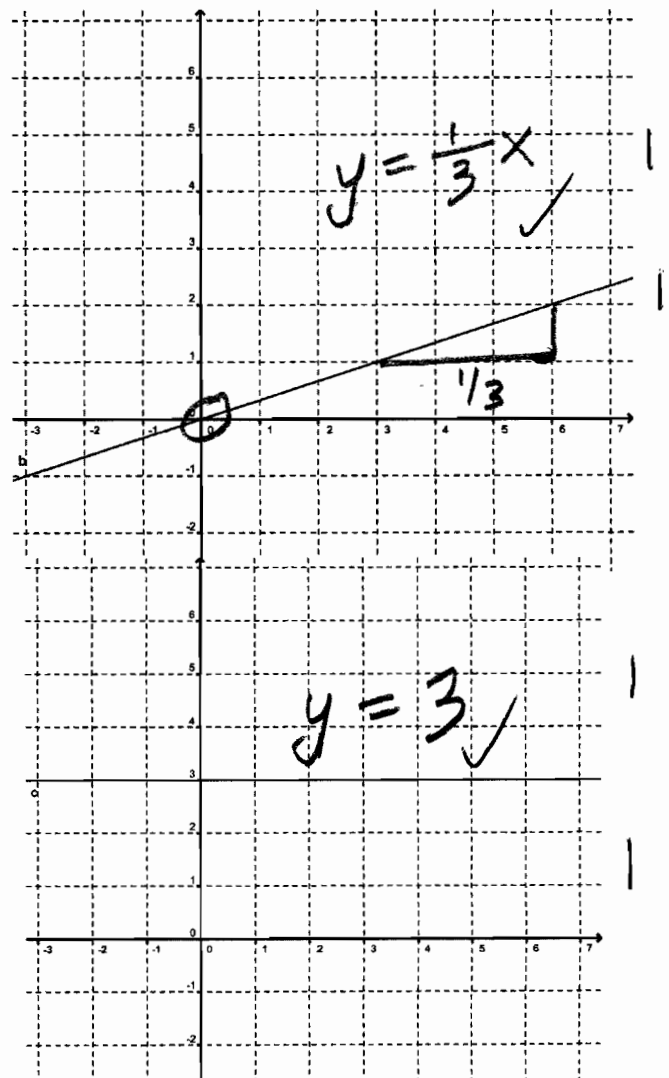
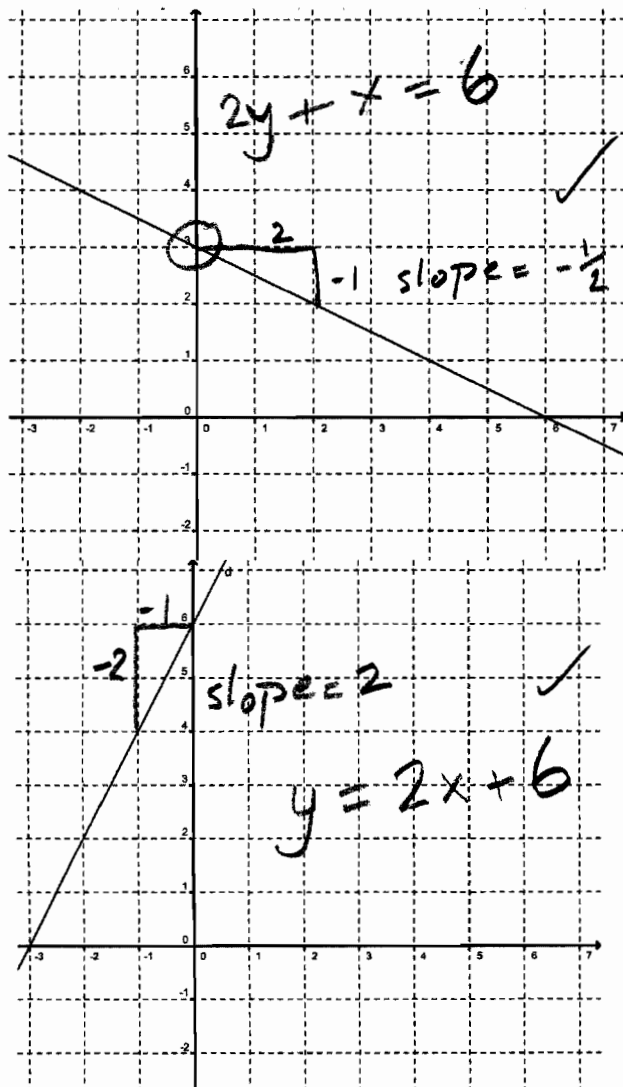

$$y = -\frac{1}{2}x + 0$$

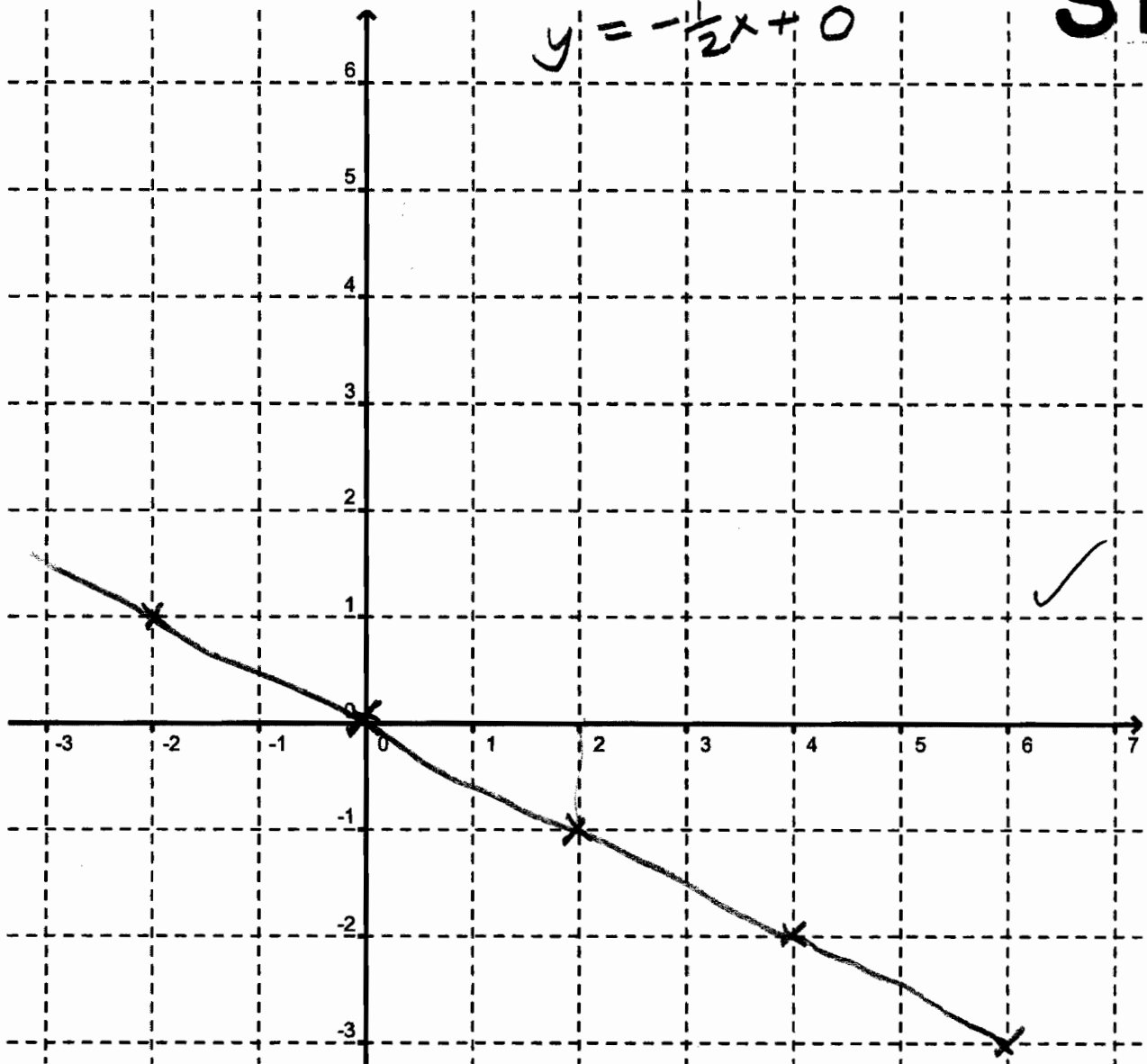

2. a. Which equation could represent the speed of someone walking steadily?
Explain your reasoning.

$$y = 3$$

The x can be time or distance and the y is speed which is steady at 3 mph.

- b. Which equation could represent the conversion between two different monetary currencies?

$$y = \frac{1}{3}x$$